

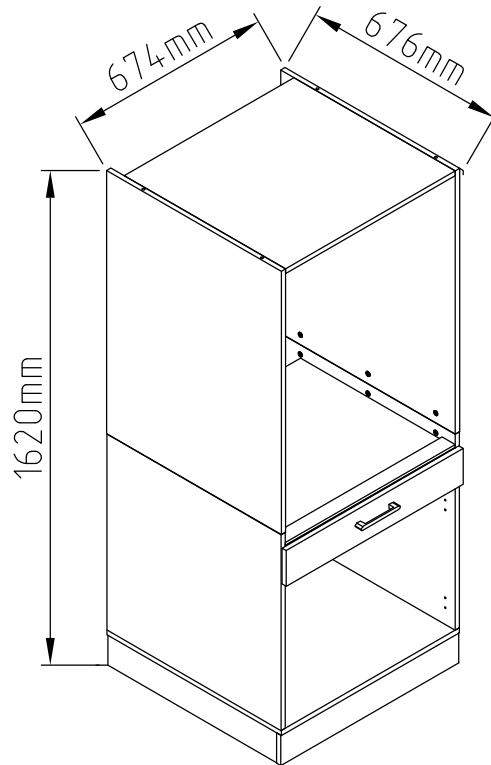

Familienunternehmen seit 1979

Family Business since 1979



Customer Service

www.vcm.group/service | e-Mail service@vcm-gruppe.de

**Service
Retoure**



**Support
Return**



ARTICLE NO

921270 921271 921272 921273 V1

#099

**ATTENTION!**

CONSIGNES DE SÉCURITÉ IMPORTANTES



Pour votre sécurité, respectez les consignes suivantes et conservez-les précieusement.

Pour éviter tout dommage corporel ou matériel, le meuble doit être solidement monté/fixé au mur. Un montage non adapté présente un risque de blessure.

Les ferrures pour la fixation murale ne sont pas comprises dans la livraison, car elles dépendent de la nature des murs.

Utilisez uniquement des ferrures adaptées à votre mur. Si vous avez des questions sur le matériel de fixation approprié, veuillez contacter votre revendeur spécialisé de confiance

OPASNOST!

NE SIGURNOSNE UPUTE



Radi vaše sigurnosti, slijedite upute u nastavku i čuvajte ih na sigurnom mjestu.

Kako biste izbjegli tjelesne ozljede ili oštećenje imovine, komad namještaja mora biti čvrsto montiran/pričvršćen na zid. Neispravno sastavljanje može dovesti do ozljeda.

Oprema za zidnu montažu nije uključena jer ovisi o stanju zidova.

Koristite samo hardver koji je prikladan za vaš zid. Ako imate pitanja o ispravnom materijalu za pričvršćivanje, obratite se svom lokalnom prodavaču.

ВНИМАНИЕ!

ВАЖНЫЕ УКАЗАНИЯ ПО БЕЗОПАСНОСТИ



Для вашей безопасности соблюдайте следующие инструкции и храните их в надежном месте.

Во избежание травм или повреждения имущества предмет мебели должен быть прочно установлен/прикреплён к стене. Неправильный монтаж может привести к травмам.

Фурнитура для крепления к стене не входит в комплект поставки, поскольку она зависит от состояния стен.

Используйте только ту фурнитуру, которая подходит для вашей стены. Если у вас возникли вопросы о правильном крепежном материале, обратитесь к местному дилеру.

ACHTUNG!

WICHTIGE SICHERHEITSHINWEISE



Beachten Sie zu Ihrer Sicherheit die nachfolgenden Hinweise und bewahren Sie diese gut auf.

Um Personen- oder Sachschäden zu vermeiden, muss das Möbelstück fest an der Wand montiert/ befestigt werden. Bei unsachgemäßer Montage besteht Verletzungsgefahr.

Die Beschläge für die Wandbefestigung sind nicht im Lieferumfang enthalten, da diese von der jeweiligen Beschaffenheit der Wände abhängig sind.

Verwenden Sie ausschließlich Beschläge, die für Ihre Wand geeignet sind. Bei Fragen zum richtigen Befestigungsmaterial, kontaktieren Sie bitte den Fachhändler Ihres Vertrauens.

ATTENTIE!

BELANGRIJKE VEILIGHEIDSINSTRUCTIES



Neem voor uw veiligheid de volgende instructies in acht en bewaar ze op een veilige plaats.

Om persoonlijk letsel of schade aan eigendommen te voorkomen, moet het meubelstuk stevig aan de muur worden bevestigd. Onjuiste montage kan leiden tot letsel.

Het beslag voor de wandmontage is niet bij de levering inbegrepen, omdat het afhankelijk is van de toestand van de muren.

Gebruik alleen beslag dat geschikt is voor uw muur. Als u vragen heeft over het juiste bevestigingsmateriaal, neem dan contact op met uw plaatselijke dealer.

ОПАСНОСТ!

ВАЖНА БЕЗБЕДНОСНА УПУТСТВА



Ради ваше безбедности, придржавајте се следећих упутстава и чувајте их.

Да бисте избегли личне повреде или оштећење имовине, комад намештаја мора бити чврсто монтиран/фиксиран за зид. Постоји опасност од повреда у случају неправилне инсталације.

Прикључци за зидну монтажу нису укључени у обим испоруке, јер зависе од одговарајућег стања зидова.

Користите само арматуре које одговарају вашем зиду. Ако имате било каквих питања о правом материјалу за причвршћивање, обратите се свом поузданом специјализованом продавцу.

ВНИМАНИЕ!

ВАЖНИ ИНСТРУКЦИИ ЗА БЕЗОПАСНОСТ



За вашата безопасност спазвайте следните инструкции и ги съхранявайте на сигурно място.

За да се избегнат лични наранявания или материални щети, мебелите трябва да бъдат здраво монтирани/фиксираны към стената. Неправилният монтаж може да доведе до нараняване.

Обхватът за монтаж на стената не е включен в обхвата на доставката, тъй като зависи от съответното състояние на стените.

подходящ за вашата стена. Ако имате въпроси относно правилния материал за закрепване, моля, свържете се с местния си търговец.

ATTENTION!

IMPORTANT SAFETY INSTRUCTIONS



For your safety, observe the following instructions and keep them in a safe place.

To avoid personal injury or damage to property, the piece of furniture must be firmly mounted/ fixed to the wall. Improper assembly may result in injury.

The fittings for wall mounting are not included in the scope of delivery, as they depend on the respective condition of the walls.

Only use fittings that are suitable for your wall. If you have any questions about the correct fixing material, please contact your local dealer.

ATTENZIONE!

IMPORTANTI ISTRUZIONI DI SICUREZZA



Per la vostra sicurezza, osservate le seguenti istruzioni e conservatele in un luogo sicuro.

Per evitare lesioni personali o danni alle cose, il mobile deve essere montato/fissato saldamente alla parete. Un montaggio improprio può provocare lesioni.

I raccordi per il montaggio a parete non sono compresi nella fornitura, poiché dipendono dalle condizioni delle pareti.

Utilizzare solo i raccordi adatti alla propria parete. In caso di domande sul materiale di fissaggio corretto, contattare il rivenditore locale.

FIGYELEM!

FONTOS BIZTONSÁGI UTASÍTÁSOK



Az Ön biztonságá érdekében tartsa be az alábbi utasításokat, és tartsa azokat biztonságos helyen.

A személyi sérülések vagy anyagi károk elkerülése érdekében a bútordarabot szilárdan a falhoz kell szerelni/rögzíteni. A nem megfelelő összeszerelés sérülést okozhat.

A falra szereléshez szükséges szerelvények nem tartoznak a szállítási terjedelemhez, mivel azok a falak mindenkori állapotától függenek.

Csak olyan szerelvényeket használjon, amelyek alkalmasak az Ön falához. Ha bármilyen kérdése van a megfelelő rögzítőanyaggal kapcsolatban, kérjük, forduljon a helyi kereskedőhöz.

ATTENTION!

VIKTIGA SÄKERHETSANVISNINGAR



För din säkerhet bör du följa följande anvisningar och förvara dem på ett säkert ställe.

För att undvika personskador eller skador på egendom måste möbelen vara ordentligt monterad/fastgjord på väggen. Felaktigt montering kan leda till skador.

Beslagen för väggmontering ingår inte i leveransen, eftersom de beror på väggarnas respektive skick.

Använd endast beslag som är lämpliga för din vägg. Om du har några frågor om rätt fästmaterial, kontakta din lokala återförsäljare.

**UWAGA!**

WAŻNE INSTRUKCJE BEZPIECZEŃSTWA



Dla własnego bezpieczeństwa należy przestrzegać poniższych instrukcji i przechowywać je w bezpiecznym miejscu.

Aby uniknąć obrażeń ciała lub uszkodzenia mienia, mebel musi być solidnie zamontowany/przymocowany do ściany. Nieprawidłowy montaż może spowodować obrażenia.

Okucia do montażu na ścianie nie wchodzą w zakres dostawy, ponieważ zależą one od odpowiedniego stanu ścian.

Należy używać wyłącznie mocowań odpowiednich do danej ściany. W przypadku pytań dotyczących właściwego materiału mocującego należy skontaktować się z lokalnym sprzedawcą.

POZOR!

DŹLEŻITÉ BEZPEČNOSTNÍ POKYNY



V zájmu své bezpečnosti dodržujte následující pokyny a uschovejte je na bezpečném místě.

Aby nedošlo ke zranění osob nebo poškození majetku, musí být kus nábytku pevně namontován/upevněn ke stěně. Nesprávná montáž může mít za následek zranění.

Kování pro montáž na stěnu není součástí dodávky, protože závisí na příslušném stavu stěn.

Používejte pouze kování, které je vhodné pro vaši stěnu. V případě dotazů ohledně správného upevňovacího materiálu se obraťte na místního prodejce.

NEBEZPEČENSTVO!

DŹLEŻITÉ BEZPEČNOSTNÉ POKYNY



V záujme vašej bezpečnosti dodržiavajte nasledujúce pokyny a uschovajte ich na bezpečnom mieste.

Aby sa predišlo zraneniu osôb alebo poškodeniu majetku, musí byť nábytok pevne namontovaný/pripevnený k stene. Nesprávna montáž môže mať za následok zranenie.

Kovanie na montáž na stenu nie je súčasťou dodávky, pretože závisí od príslušného stavu stien.

Používajte len kovania, ktoré sú vhodné pre vašu stenu. Ak máte otázky týkajúce sa správneho upevňovacieho materiálu, obráťte sa na miestneho predajcu.

ATENȚIE!

INSTRUCȚIUNI IMPORTANTE DE SIGURANȚĂ



Pentru siguranța dumneavoastră, respectați următoarele instrucțiuni și păstrați-le într-un loc sigur.

Pentru a evita rănirea persoanelor sau deteriorarea bunurilor, piesa de mobilier trebuie să fie montată/fixată ferm pe perete. Montarea necorespunzătoare poate duce la rănire.

Accesoriiile pentru montarea pe perete nu sunt incluse în volumul de livrare, deoarece acestea depind de starea respectivă a pereților.

Folosiți numai fitinguri adecvate pentru peretele dumneavoastră. Dacă aveți întrebări cu privire la materialul de fixare corect, vă rugăm să vă adresați distribuitorului local.

DİKKAT!

ÖNEMLİ GÜVENLİK TALİMATLARI



Güvenliğiniz için aşağıdaki talimatlara uyun ve bunları güvenli bir yerde saklayın.

Kişisel yaralanma veya maddi hasarı önlemek için, mobilya parçası duvara sıkıca monte edilmeli/sabitlenmelidir. Yanlış montaj yaralanmalara neden olabilir.

Duvara montaj için gerekli bağlantı parçaları, duvarların durumuna bağlı olduğundan teslimat kapsamına dahil değildir.

Sadece duvarınız için uygun olan bağlantı parçalarını kullanın. Doğru sabitleme malzemesi hakkında herhangi bir sorunuz varsa, lütfen yerel satıcınızla iletişime geçin.

ATENCIÓN!

INSTRUCCIONES IMPORTANTES DE SEGURIDAD



Por su seguridad, observe las siguientes instrucciones y guárdelas en un lugar seguro.

Para evitar lesiones personales o daños materiales, el mueble debe estar firmemente montado/fijado a la pared. Un montaje incorrecto puede provocar lesiones.

Los herrajes para el montaje mural no están incluidos en el volumen de suministro, ya que dependen del estado respectivo de las paredes.

Utilice únicamente herrajes adecuados para su pared. Si tiene alguna duda sobre el material de fijación correcto, póngase en contacto con su distribuidor local.

ATENÇÃO!

INSTRUÇÕES DE SEGURANÇA IMPORTANTES



Para sua segurança, respeite as instruções seguras e guarde-as num local seguro.

Para evitar ferimentos pessoais ou danos materiais, a peça de mobiliário deve ser montada/fixada firmemente na parede. Uma montagem incorreta pode provocar ferimentos.

Os acessórios para a montagem na parede não estão incluídos no âmbito do fornecimento, uma vez que dependem do estado das paredes.

Utilize apenas os acessórios adequados à sua parede. Se tiver alguma dúvida sobre o material de fixação correcto, contacte o seu revendedor local.

УВАГА!

ВАЖЛИВІ ВКАЗІВКИ З БЕЗПЕКИ



Задля вашої безпеки дотримуйтесь наведених нижче інструкцій і зберігайте їх у безпечному місці.

Щоб уникнути травм або пошкодження майна, предмет меблів повинен бути міцно встановлений/прикріплений до стіни. Неправильний монтаж може призвести до травм.

Кріплення для настінного монтажу не входить в комплект поставки, оскільки воно залежить від стану стін.

Використовуйте тільки ті кріплення, які підходять для вашої стіни. Якщо у вас виникли запитання щодо правильного кріпильного матеріалу, зверніться до місцевого дилера.

OBS!

VIGTIGE SIKKERHEDSANVISNINGER



Af hensyn til din sikkerhed skal du overholde de følgende instruktioner og opbevare dem et sikkert sted.

For at undgå personskade eller beskadigelse af ejendom skal møblet være solidt monteret/fastgjort til væggen. Forkert montering kan medføre personskade.

Beslagene til vægmontering er ikke inkluderet i leveringsomfanget, da de afhænger af den respektive tilstand af væggene.

Brug kun beslag, der er egnet til din væg. Hvis du har spørgsmål om det korrekte fastgørelsesmateriale, bedes du kontakte din lokale forhandler.

OPPMERKSOMHET!

VIKTIGE SIKKERHETSANVISNINGER



For din egen sikkerhet må du følge følgende instruksjoner og oppbevare dem på et trygt sted.

For å unngå personskader eller materielle skader må møbelet monteres/festes godt til veggen. Feil montering kan føre til personskader.

Beslagene for veggmontering er ikke inkludert i leveringsomfanget, da de avhenger av veggens respektive tilstand.

Bruk kun beslag som er egnet for din vegg. Hvis du har spørsmål om riktig festemateriell, ta kontakt med din lokale forhandler.

HUOMIO!

TÄRKEITÄ TURVALLISUUSOHJEITA



Huomioi seuraavat ohjeet turvallisuutesi vuoksi ja säilytä ne turvallisessa paikassa.

Henkilövahinkojen tai omaisuusvahinkojen välttämiseksi huonekalu on asennettava/kiinnitettävä tukevasti seinään. Virheellinen kokoaminen voi aiheuttaa loukkaantumisen.

Seinäkiinnitykseen tarvittavat varusteet eivät sisälly toimitukseen, koska ne riippuvat seinien kunnosta.

Käytä vain seinään sopivia kiinnikkeitä. Jos sinulla on kysyttävää oikeasta kiinnitysmateriaalista, ota yhteyttä paikalliseen jälleenmyyjään.

ΠΡΟΣΟΧΗ!

ΣΗΜΑΝΤΙΚΕΣ ΟΔΗΓΙΕΣ ΑΣΦΑΛΕΙΑΣ











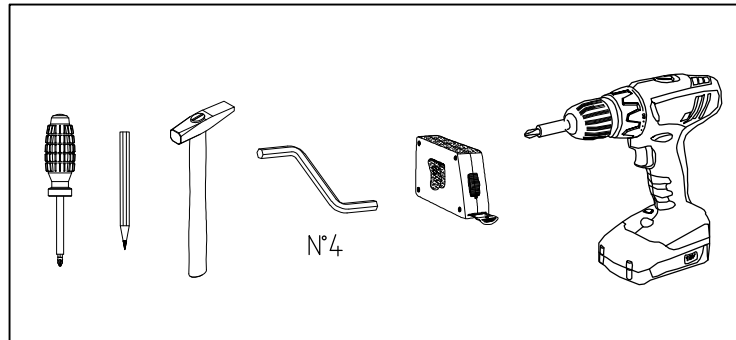
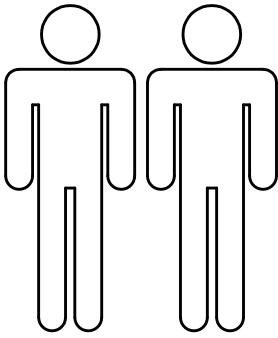

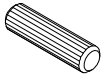
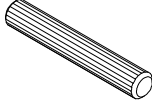

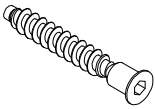
Για την ασφάλειά σας, τηρήστε τις παρακάτω οδηγίες και φυλάξτε τις σε ασφαλές μέρος.

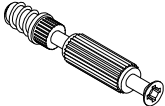
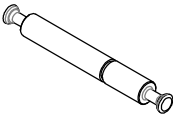
Για να αποφύγετε τραυματισμούς ή υλικές ζημιές, το έπιπλο πρέπει να είναι σταθερά τοποθετημένο/στερεωμένο στον τοίχο. Η ακατάλληλη συναρμολόγηση μπορεί να οδηγήσει σε τραυματισμό.

Τα εξαρτήματα για την τοποθέτηση στον τοίχο δεν περιλαμβάνονται στο αντικείμενο της παράδοσης, καθώς εξαρτώνται από την εκάστοτε κατάσταση των τοίχων.

Χρησιμοποιείτε μόνο εξαρτήματα που είναι κατάλληλα για τον τοίχο σας. Εάν έχετε ερωτήσεις σχετικά με το σωστό υλικό στερέωσης, επικοινωνήστε με τον τοπικό αντιπρόσωπο.

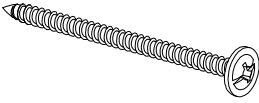

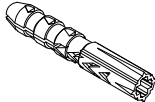
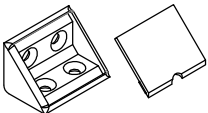
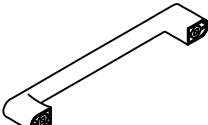
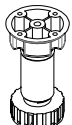
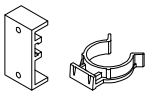
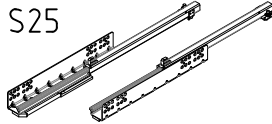
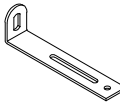
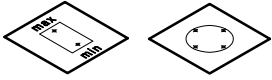

 A1 8*30mm x26	 A2 8*50mm x4	 B ϕ 12mm x10
 B1 6,3*50mm x10	 B3 ϕ 5mm x8	 C1 6*43mm x31
 C2 8*65mm x6	 D ϕ 20mm x43	 D1 15/15 x33
 D3 15/22 x10	 E6 3,5*16mm x68	 E15 4*30mm x3
 2E 4,2*16mm x8	 5E 4,2*65mm x4	 F3 5,0*13mm x6
 G9 M 4*25mm x2	 H5 8*50mm x4	 H12 20x20x33 x8
 I59 F.412.104 x1	 K2 x4	 K3 x6
Runner UM S25  M12 L-500 mm x1	 S16 77x21x15 x4	 template

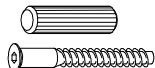

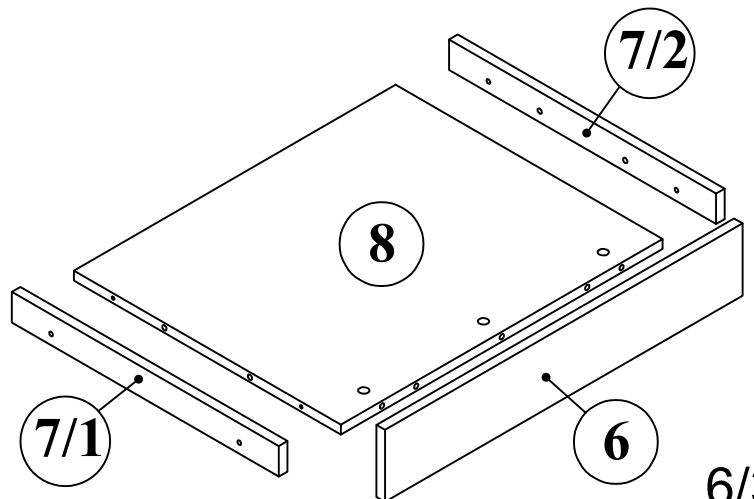
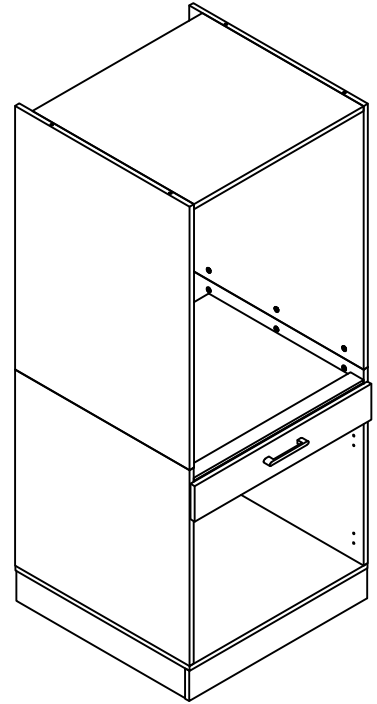
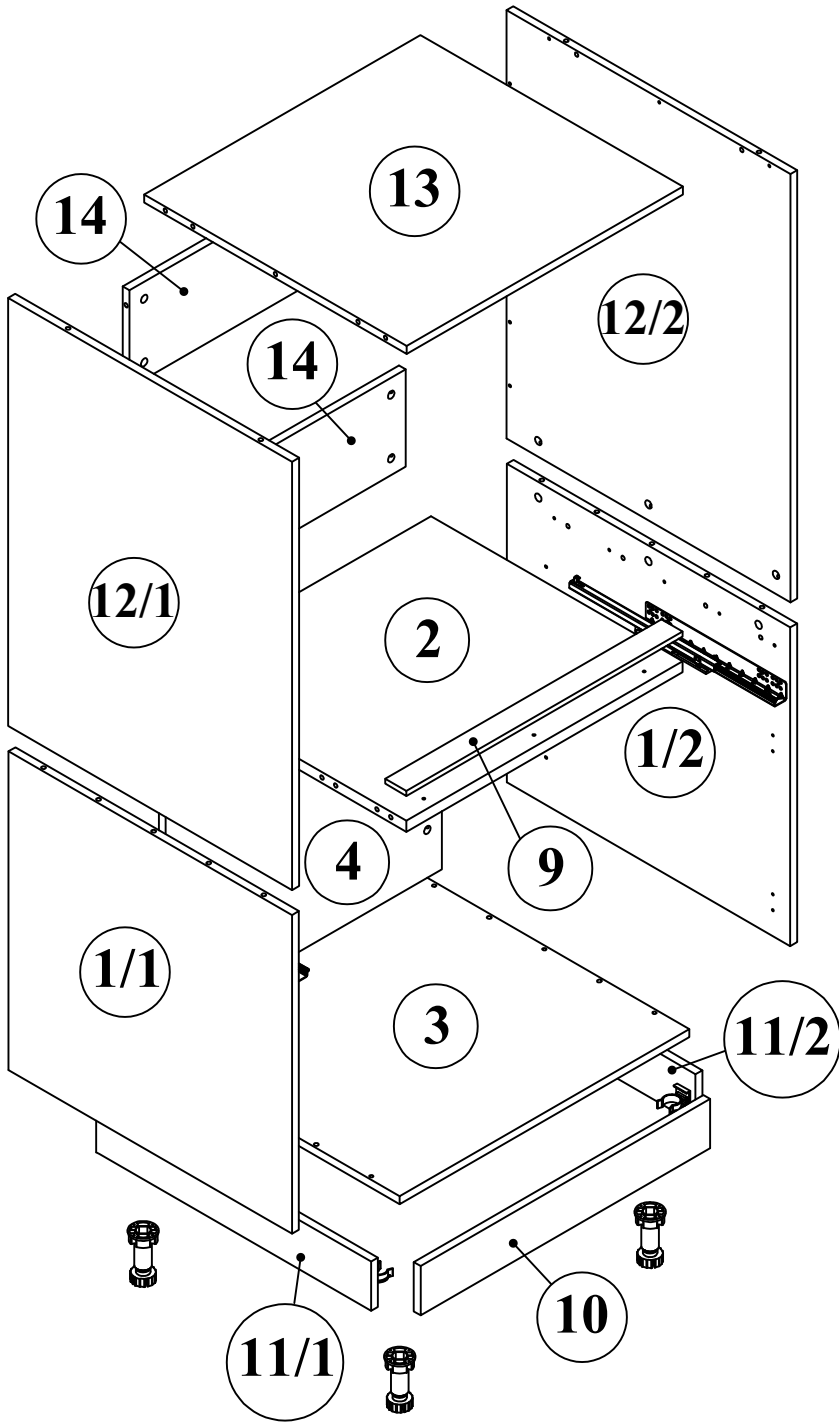
No	a*b	x	N°→...
1/1	642x660	x1	1/2
1/2	642x660	x1	1/2
2	642x586	x1	1/2
3	674x660	x1	1/2
4	642x576	x1	1/2
6	670x118	x1	1/2
7/1	500x50	x1	1/2
7/2	500x50	x1	1/2
8	602x500	x1	1/2
9	642x50	x1	1/2
10	674x100	x1	1/2
11/1	640x100	x1	1/2
11/2	640x100	x1	1/2
12/1	862x660	x1	2/2
12/2	862x660	x1	2/2
13	642x610	x1	2/2
14	642x196	x2	2/2
		x1	1/2



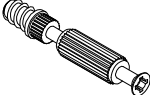

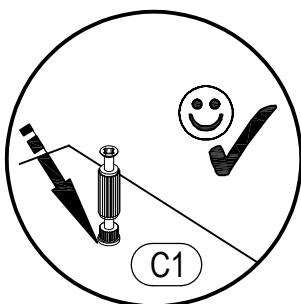
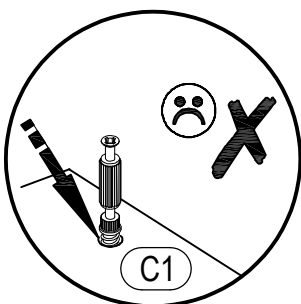
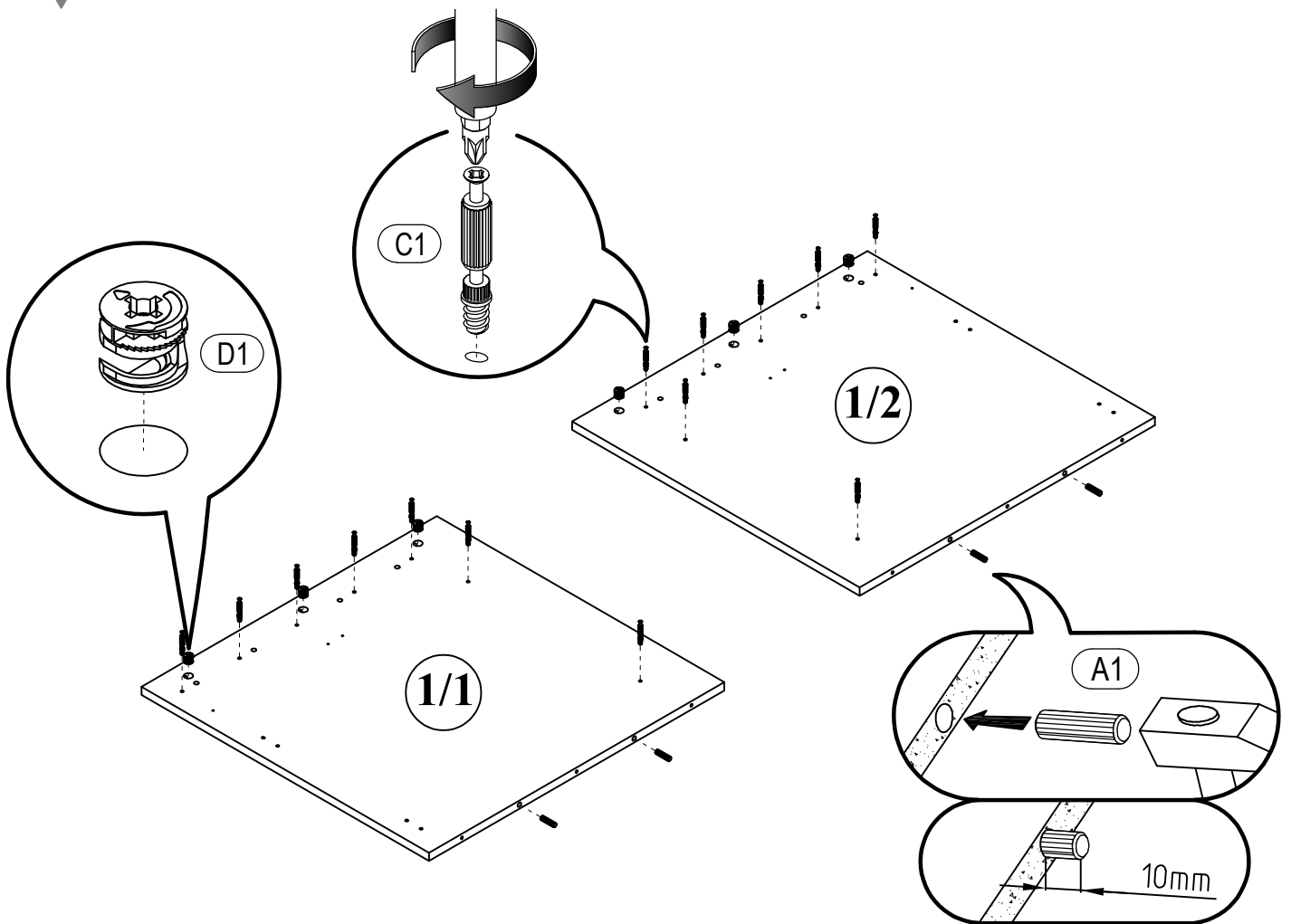

 (A1) 8*30mm x4	 (C1) 6*43mm x14	 (D1) 15/15 x6
--	---	---

1





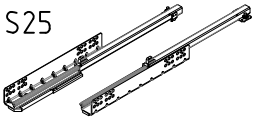

 (B3) $\varnothing 5\text{mm}$ x8	 (F3) 5,0*13mm x6	Runner UM S25  (M12) L-500 mm x1
--	--	--

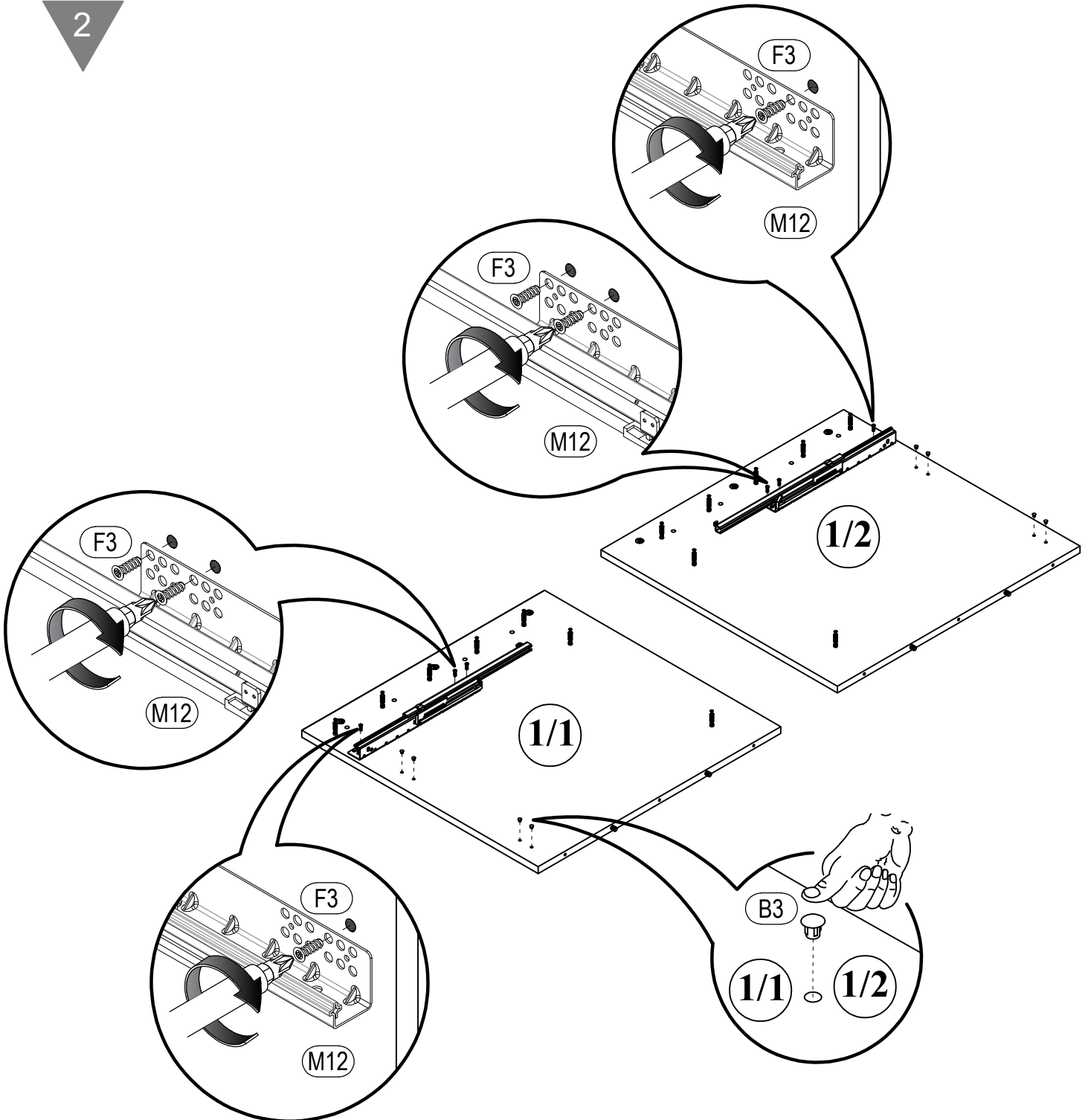
2





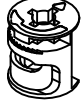

 (A1) 8*30mm x8	 (D1) 15/15 x4	 (D3) 15/22 x10
---	--	---

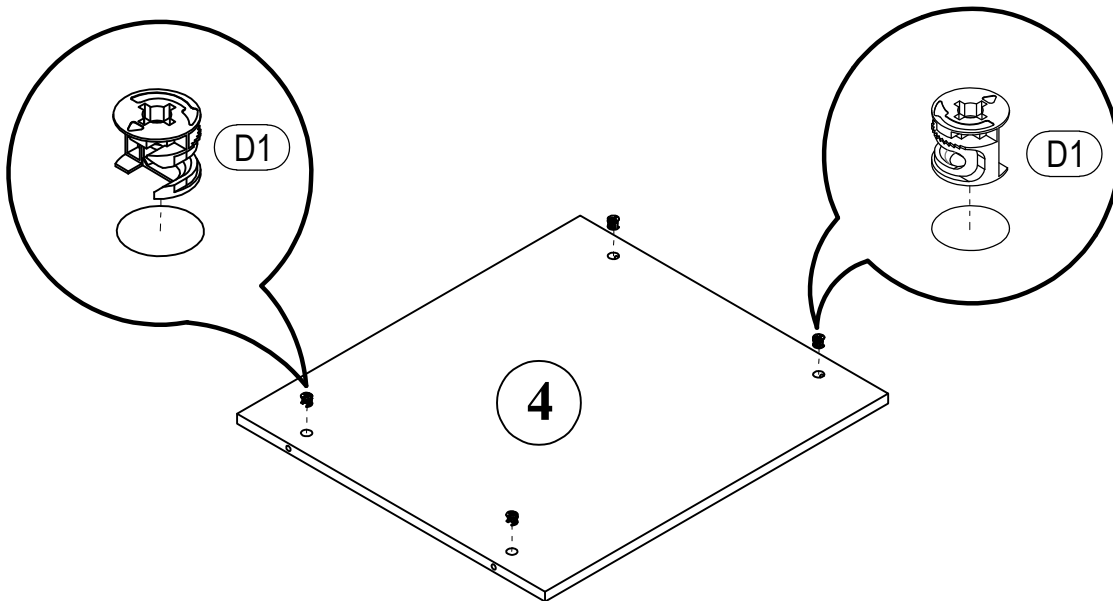
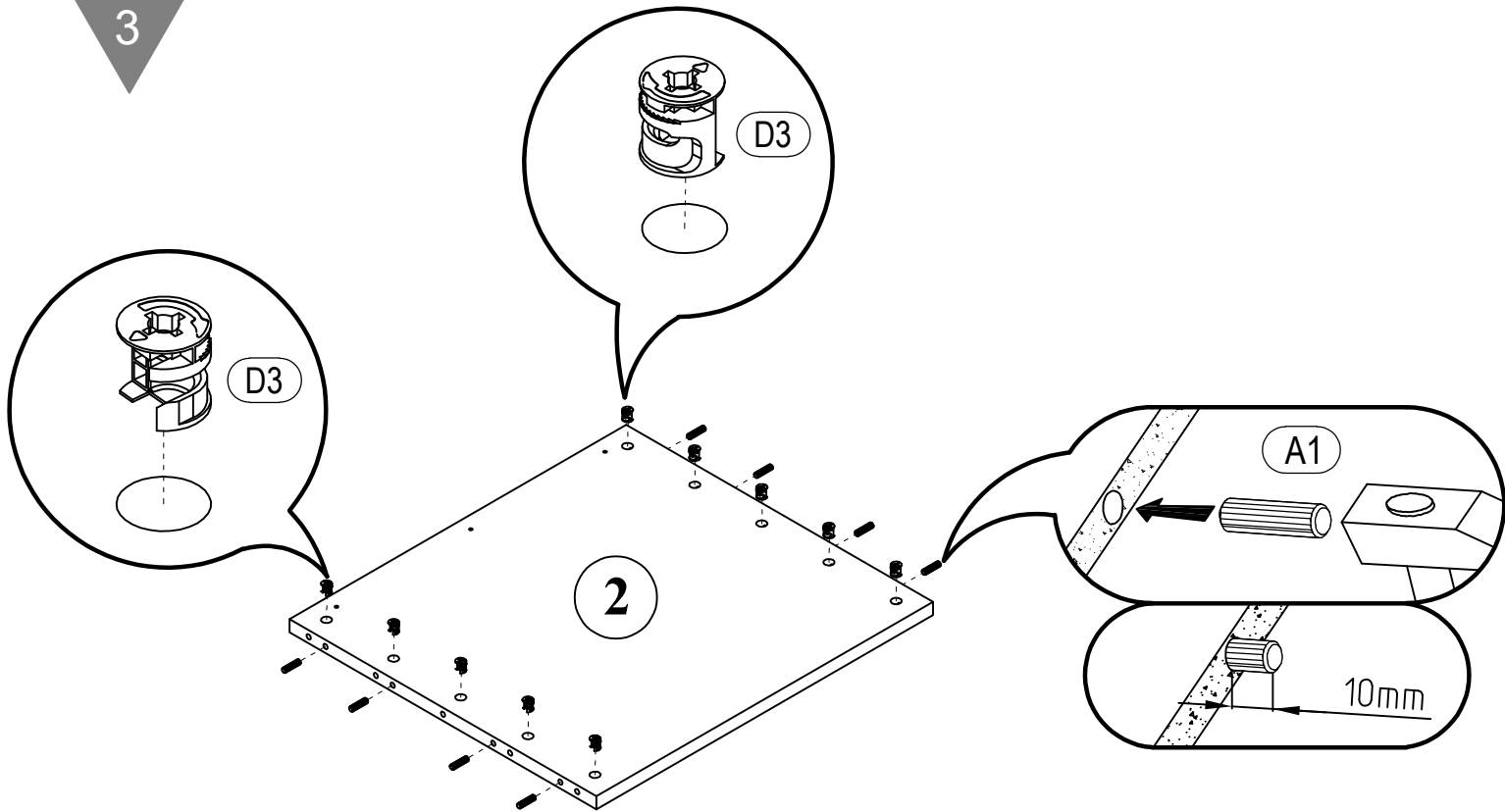
3



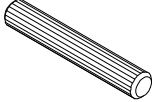

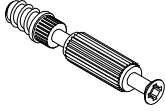
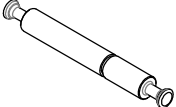

 A2 8*50mm x4	 D1 15/15 x6	 C1 6*43mm x14
 C2 8*65mm x6		

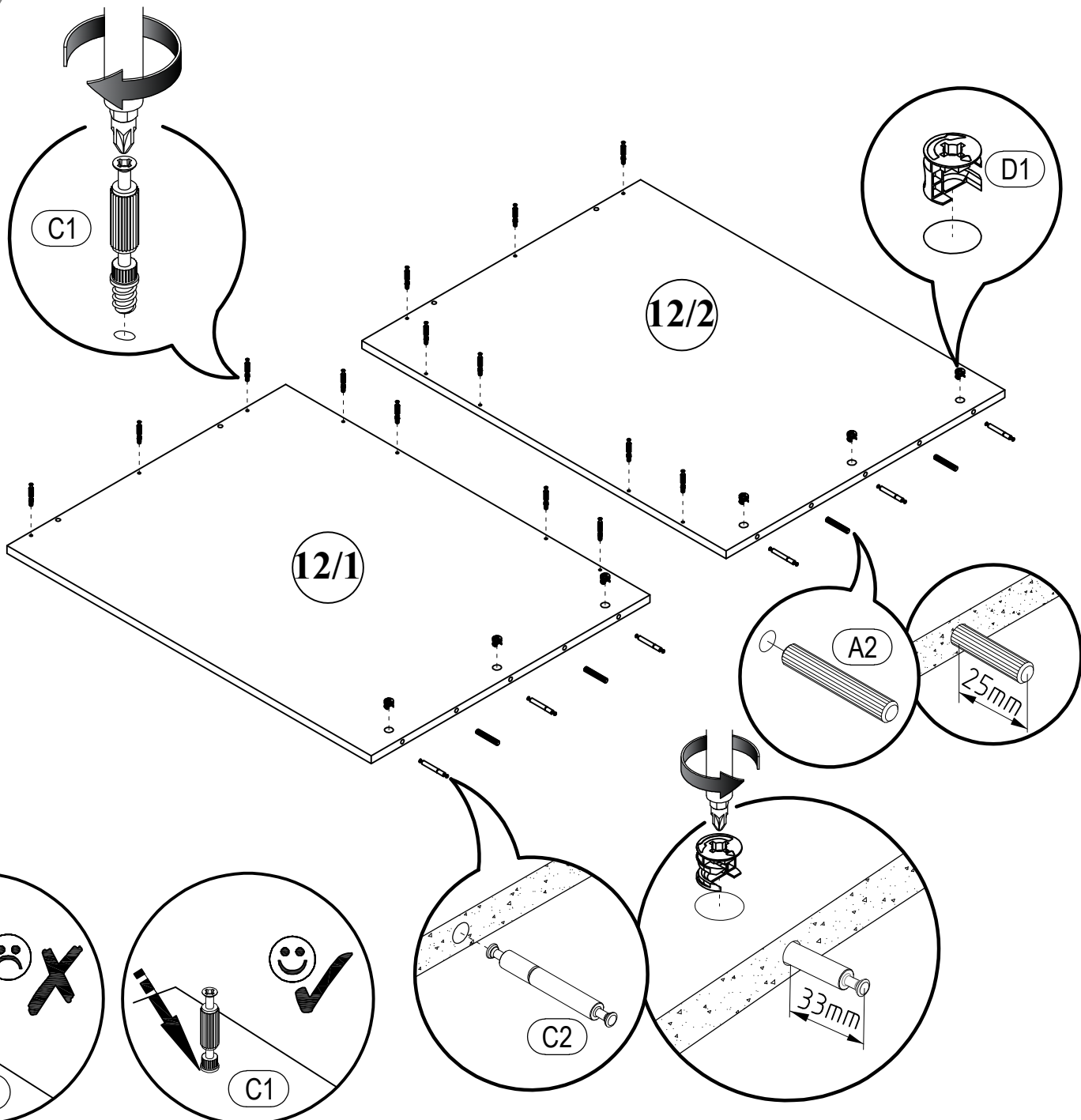
4



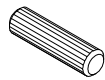

 B3 $\varnothing 5\text{mm}$ x1	 A1 8*30mm x10	 D1 15/15 x17
--	--	---

5

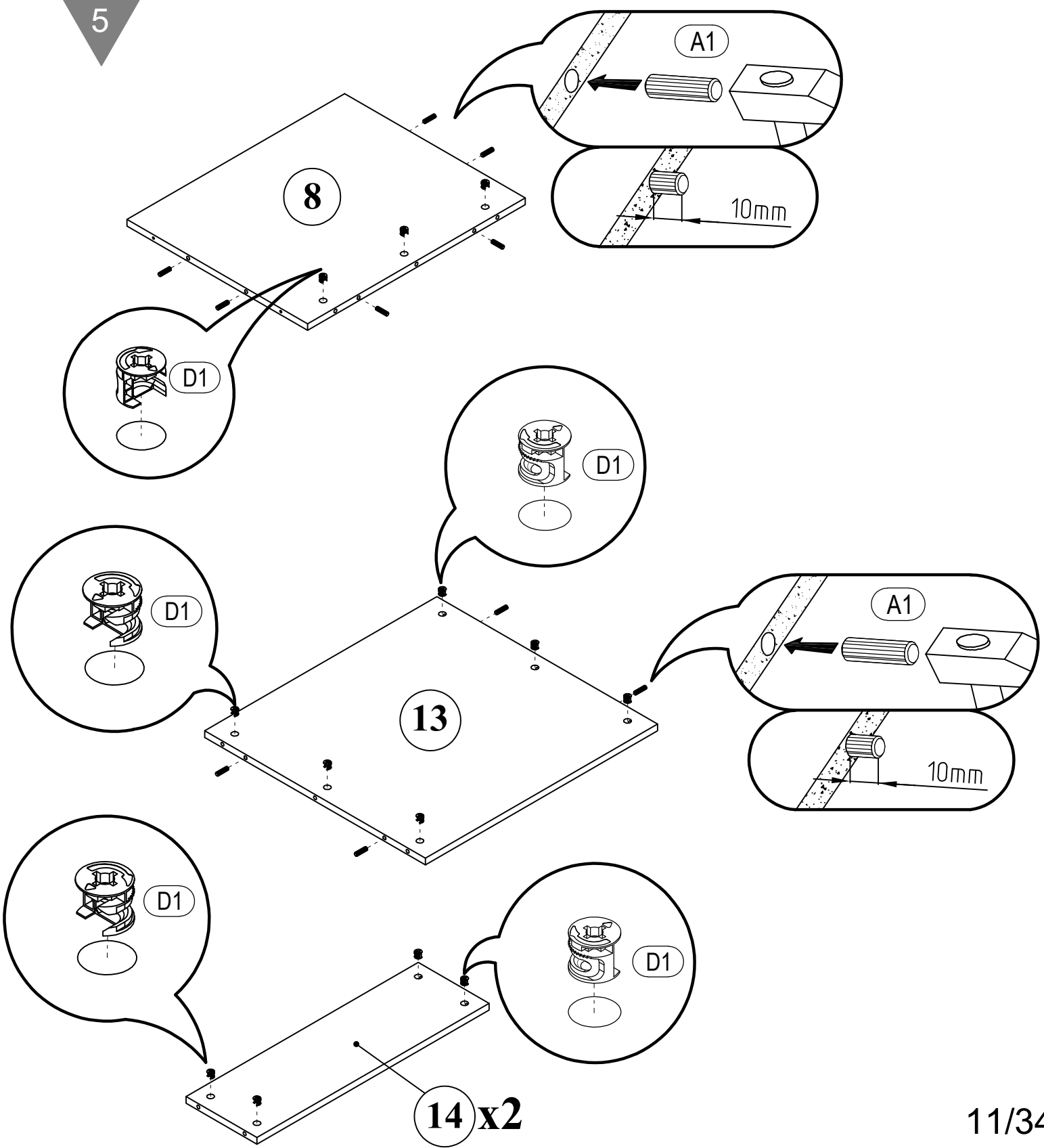

14 x2



6

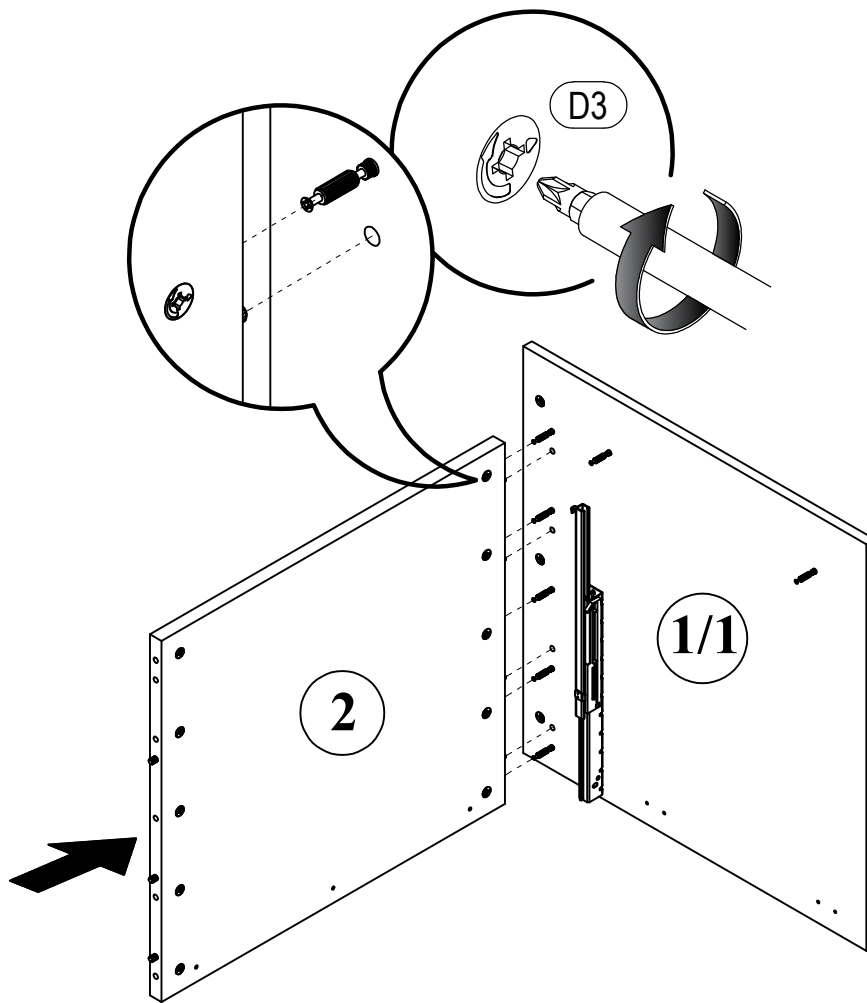

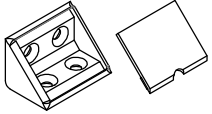

 (E6) 3,5*16mm x16	 (H12) 20x20x33 x4
--	--

7

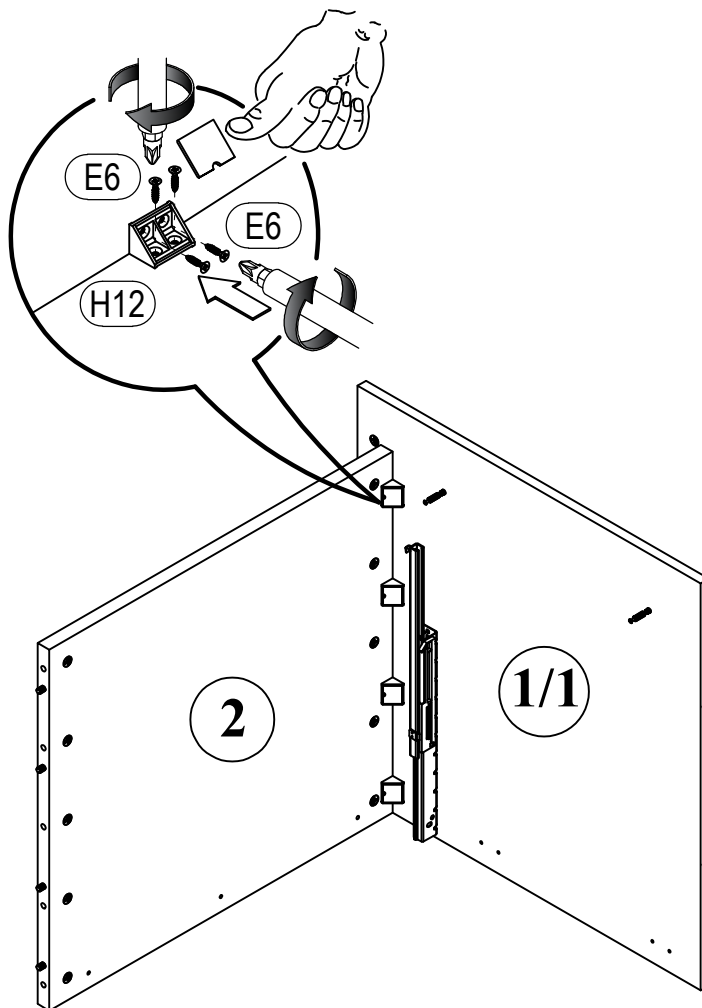



8

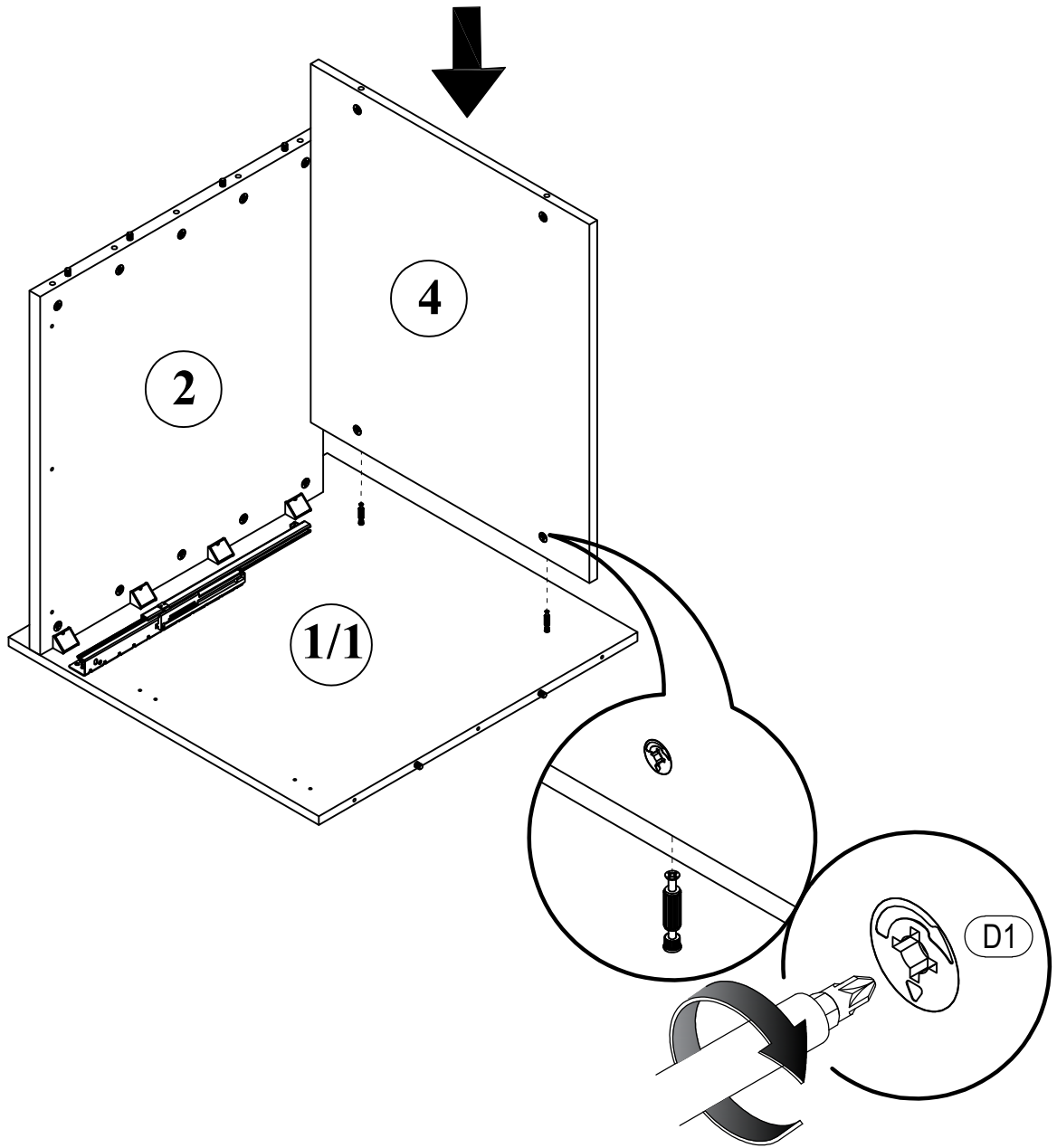

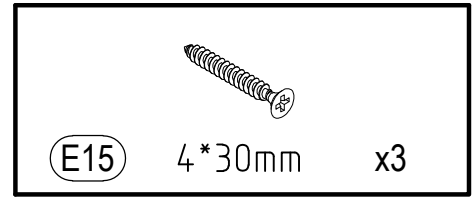

9

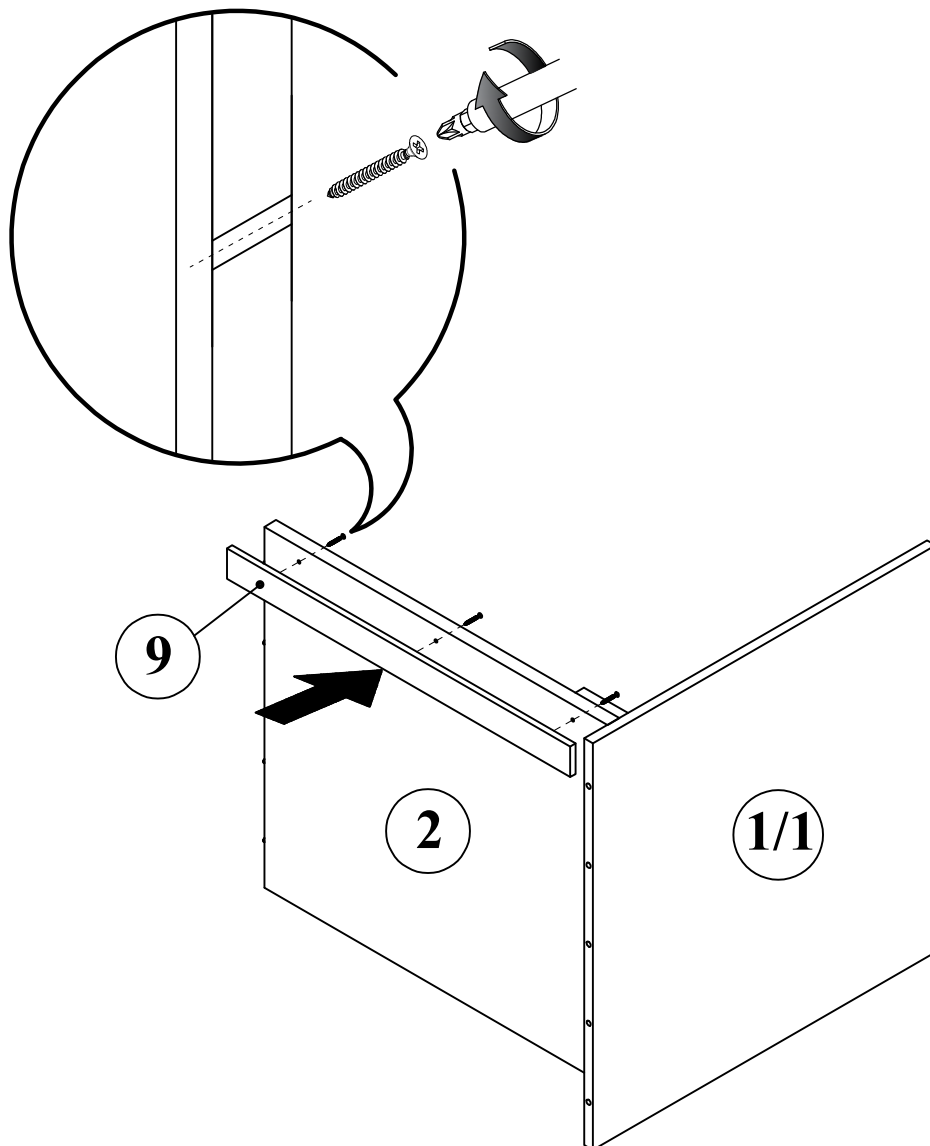



10

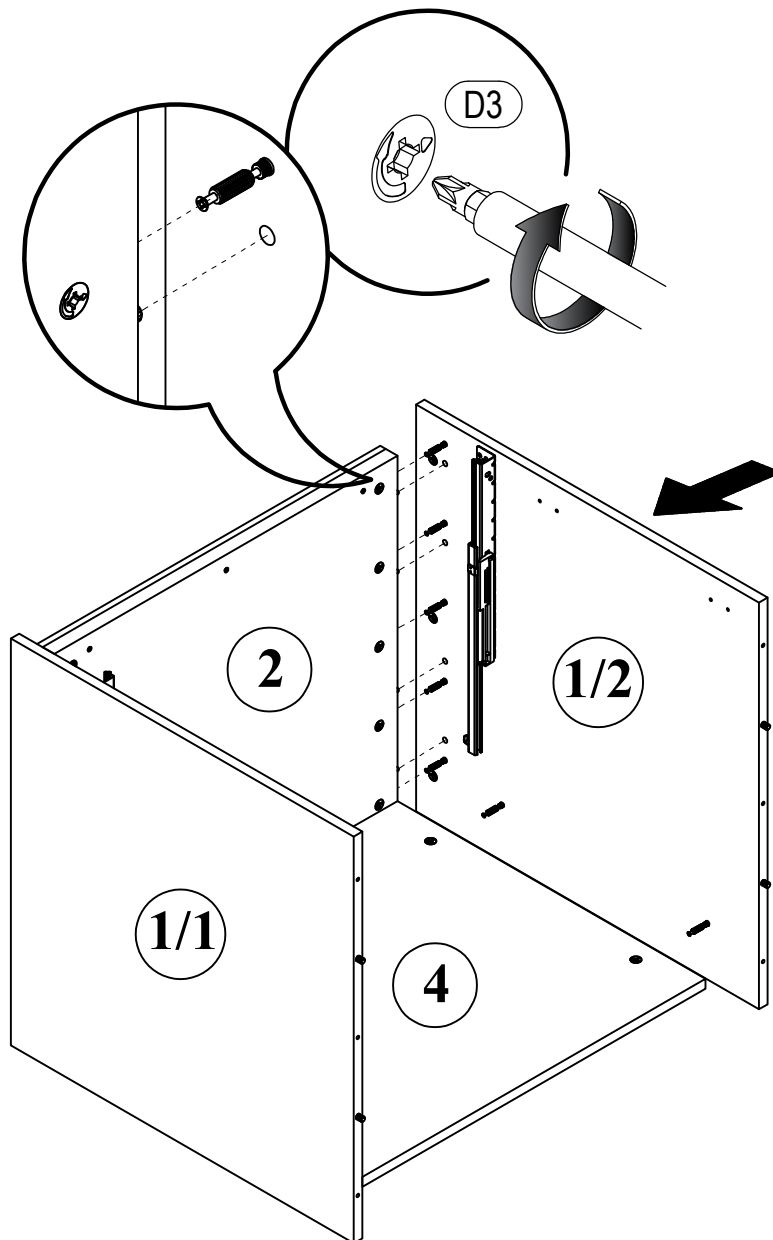

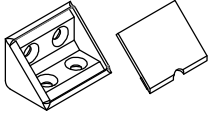

	
(E6) 3,5*16mm x16	(H12) 20x20x33 x4

11

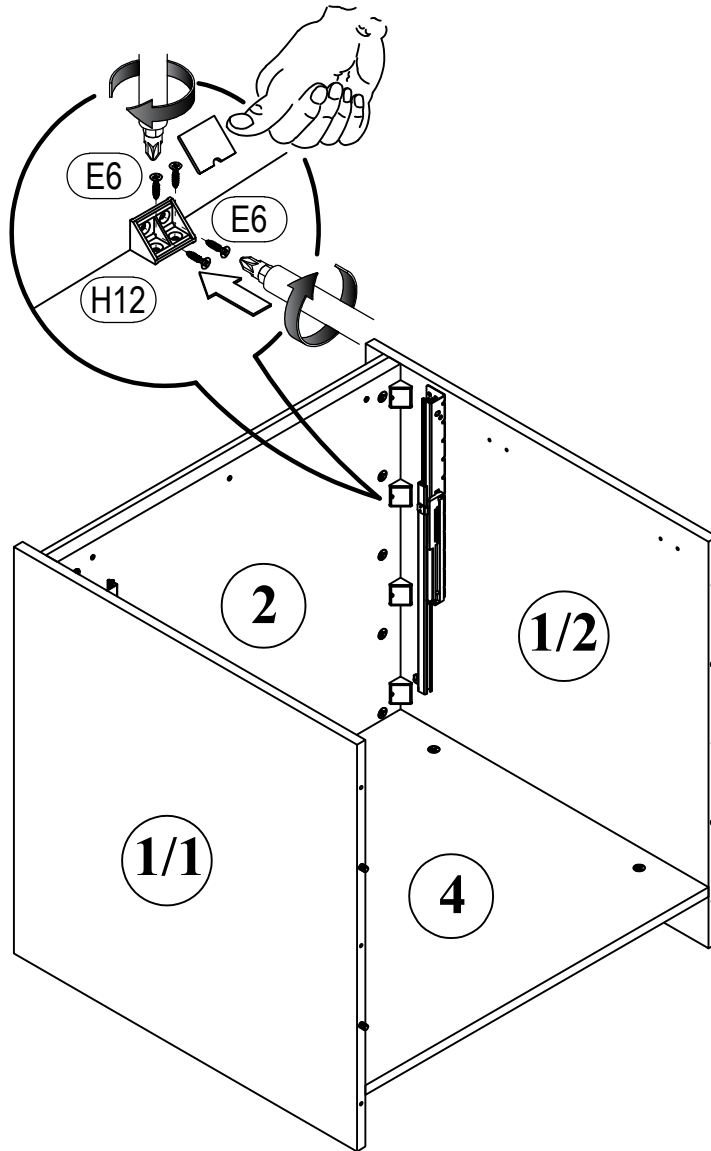



 B $\phi 12\text{mm}$ x6	 B1 6,3*50mm x6
-----------------------------	--------------------------

12

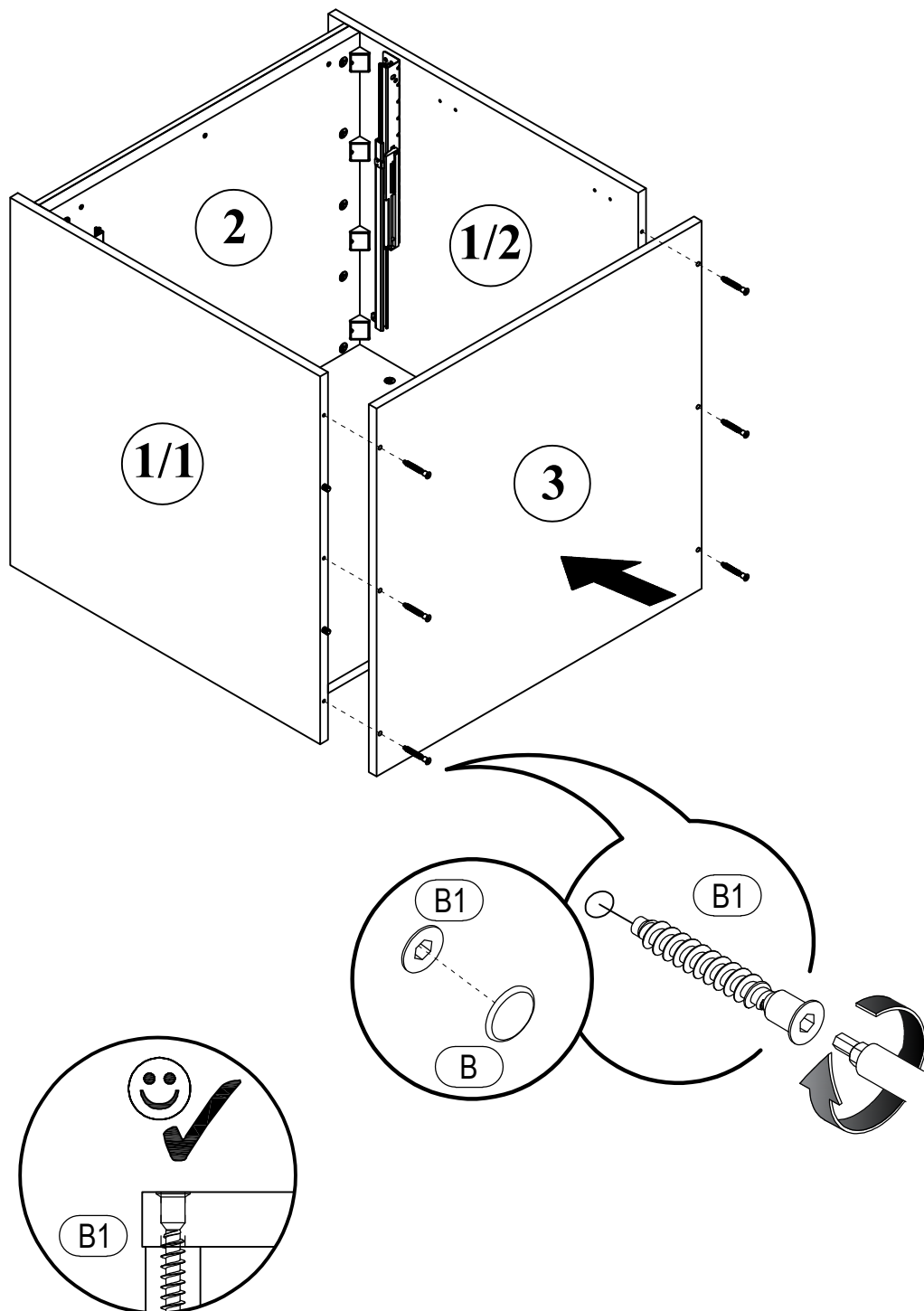

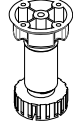
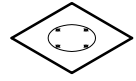

 (E6) 3,5*16mm x16	 (K2) x4	 template
--	--	---

13

Step 1

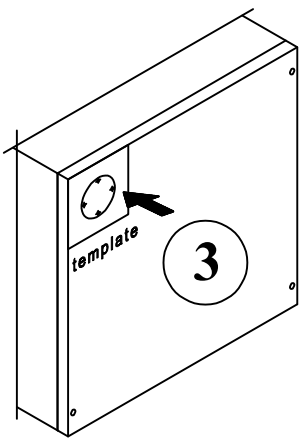

Step 2

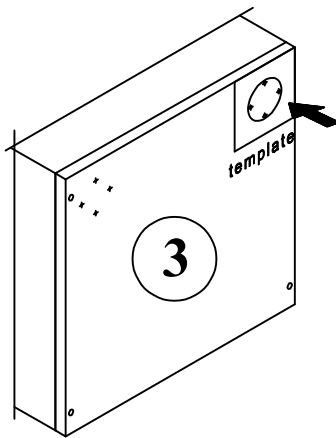

Step 3

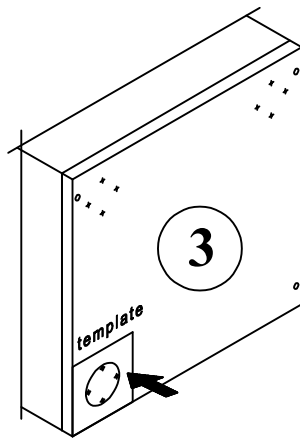

Step 4

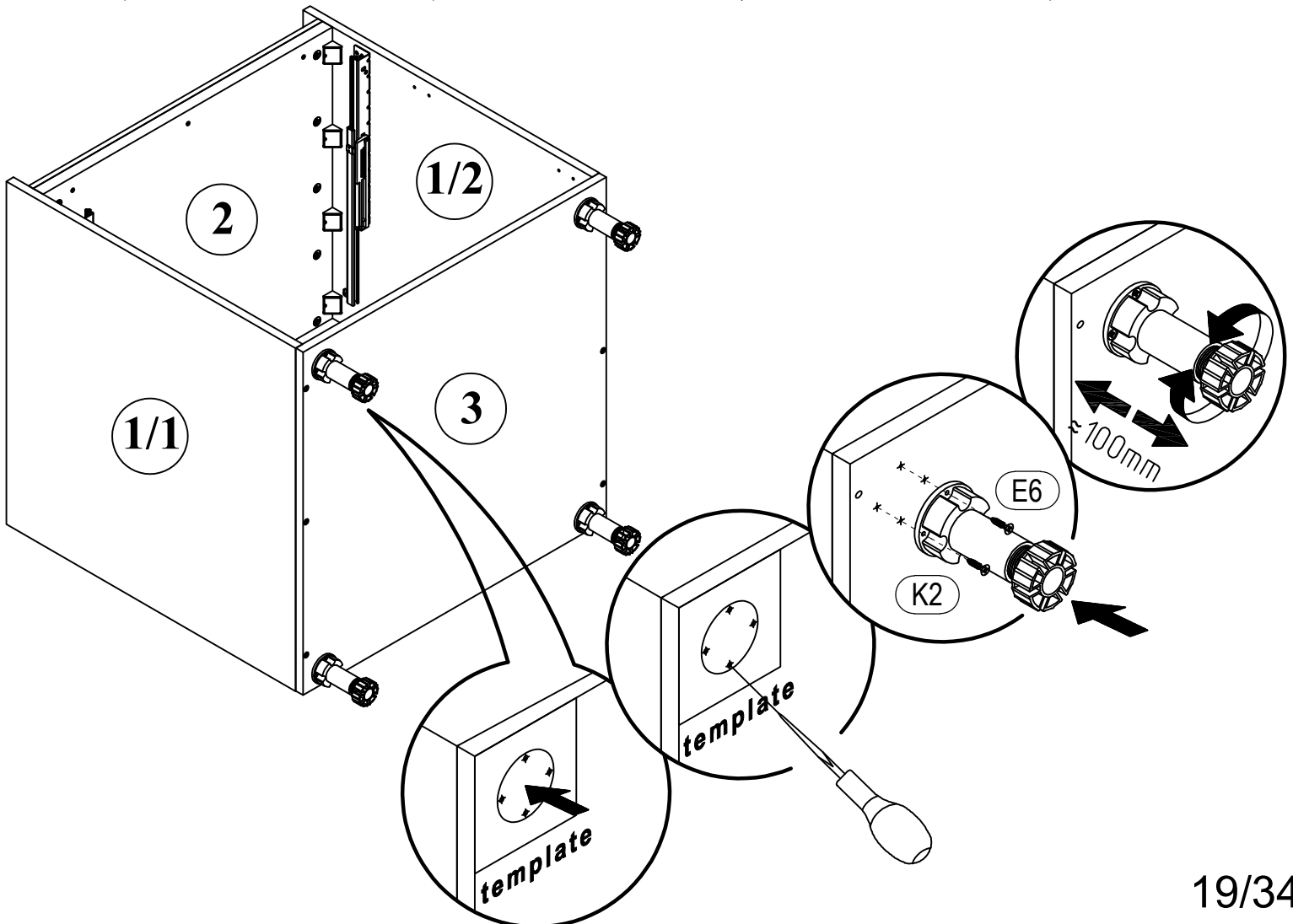
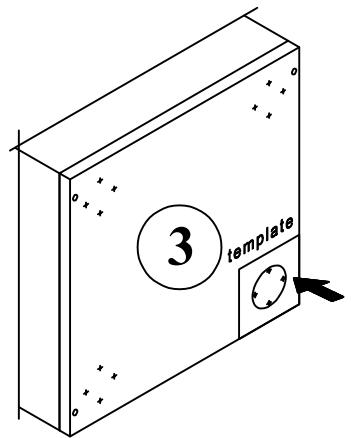

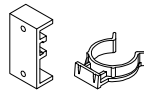
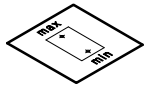

 (E6) 3,5*16mm x4	 (K3) x2	 template
---	--	---

14

Step 1

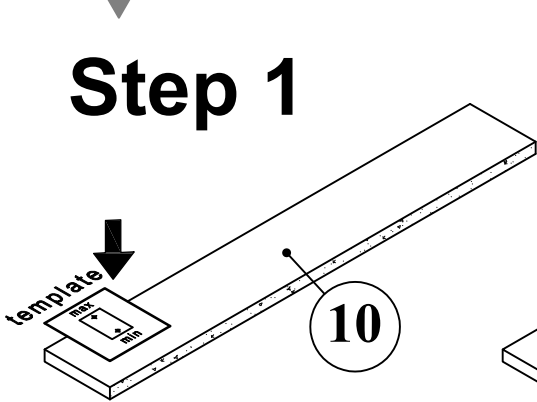

Step 2

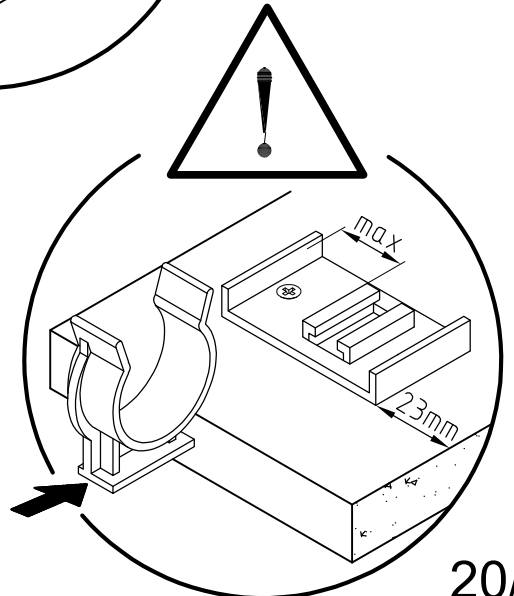
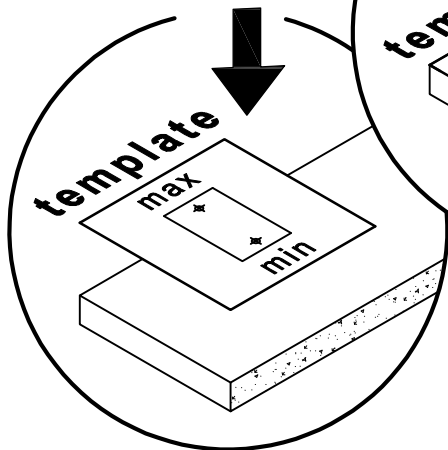
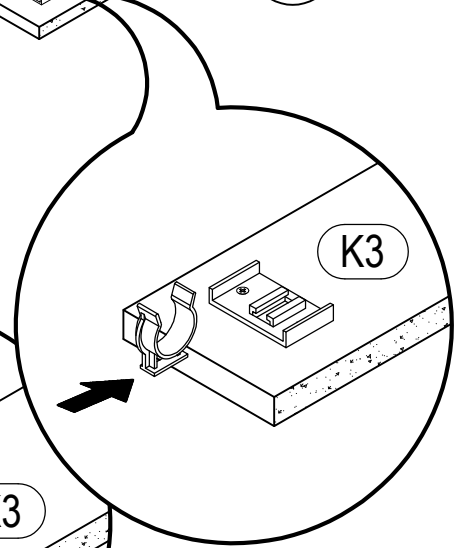
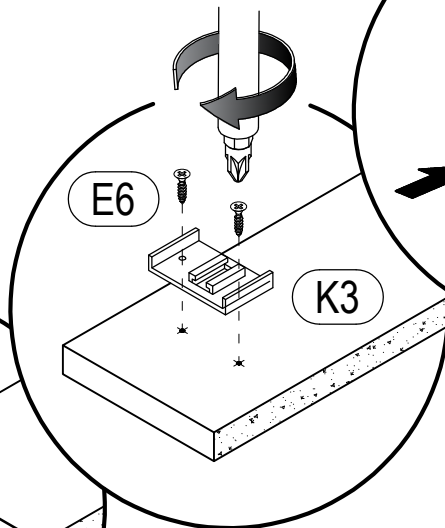
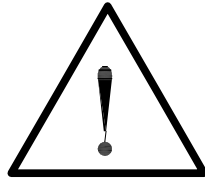
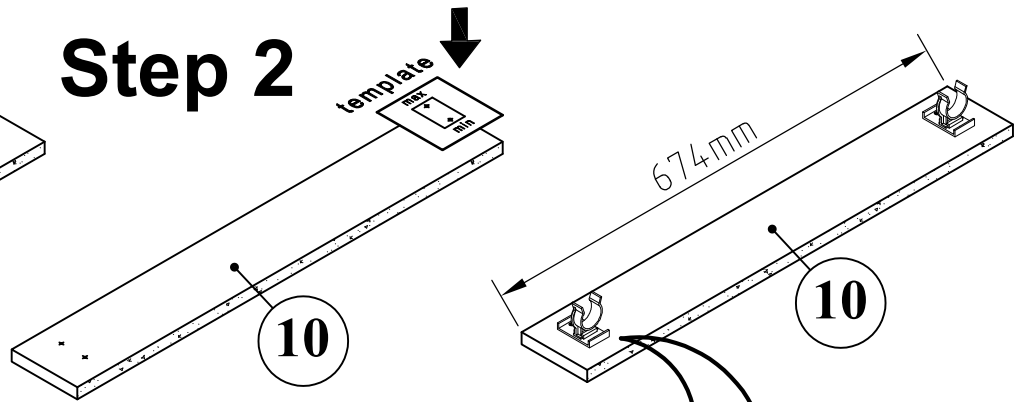

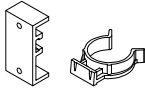
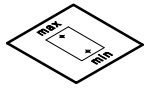

 (E6) 3,5*16mm x4	 (K3) x2	 template
---	--	---

15

x1

Step 1

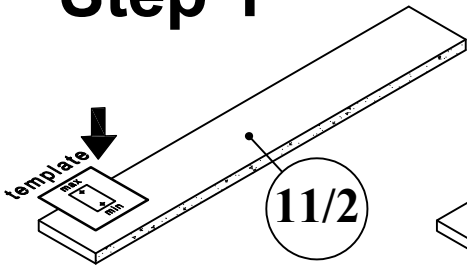

Step 2

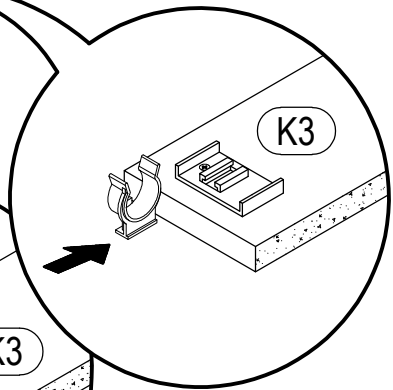
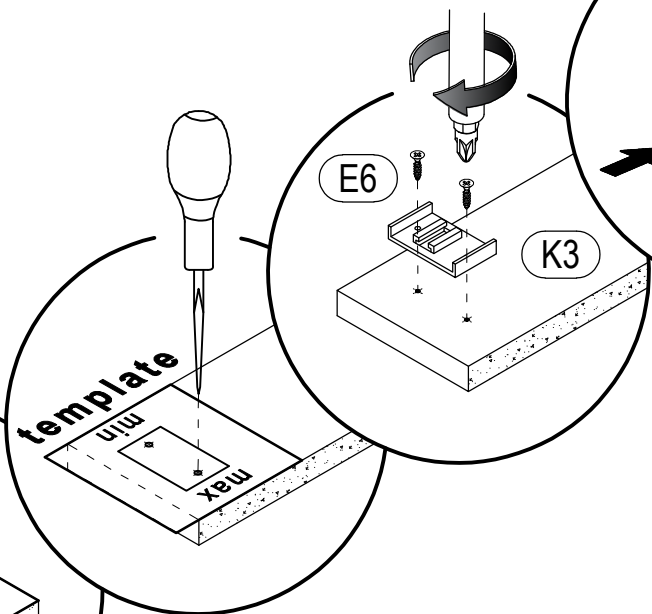
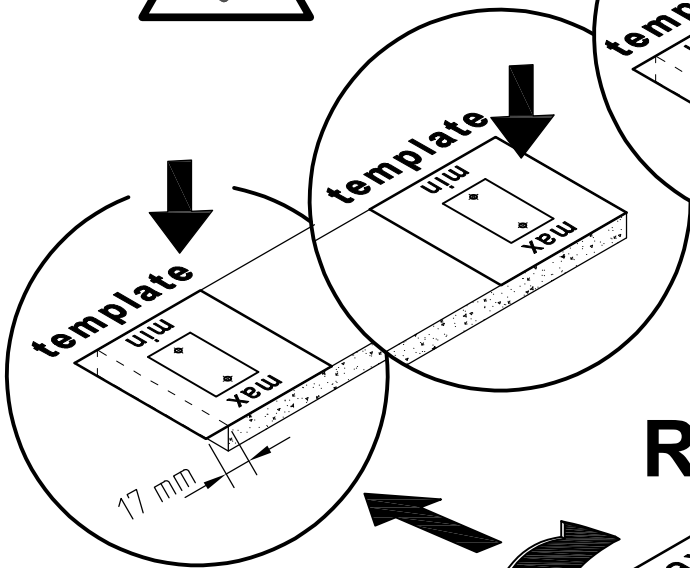
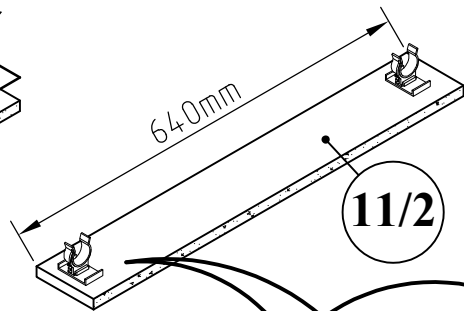
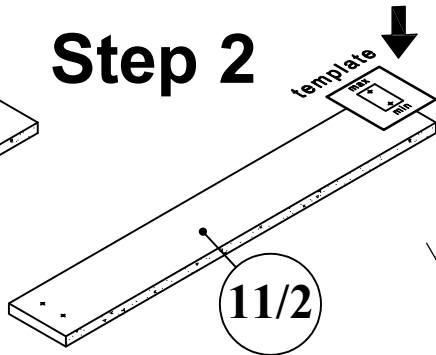

Rotate

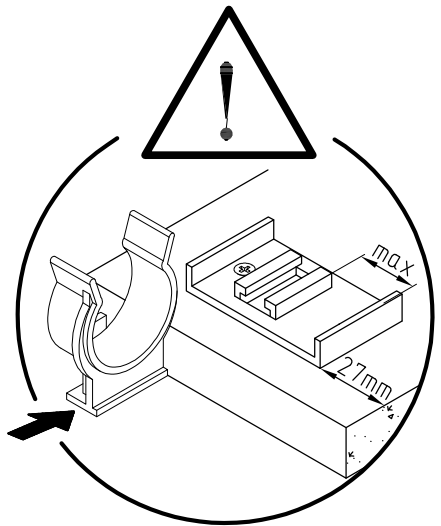

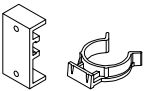
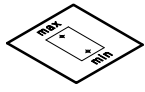

 (E6) 3,5*16mm x4	 (K3) x2	 template
---	--	---

16

x1

Step 1

Step 2

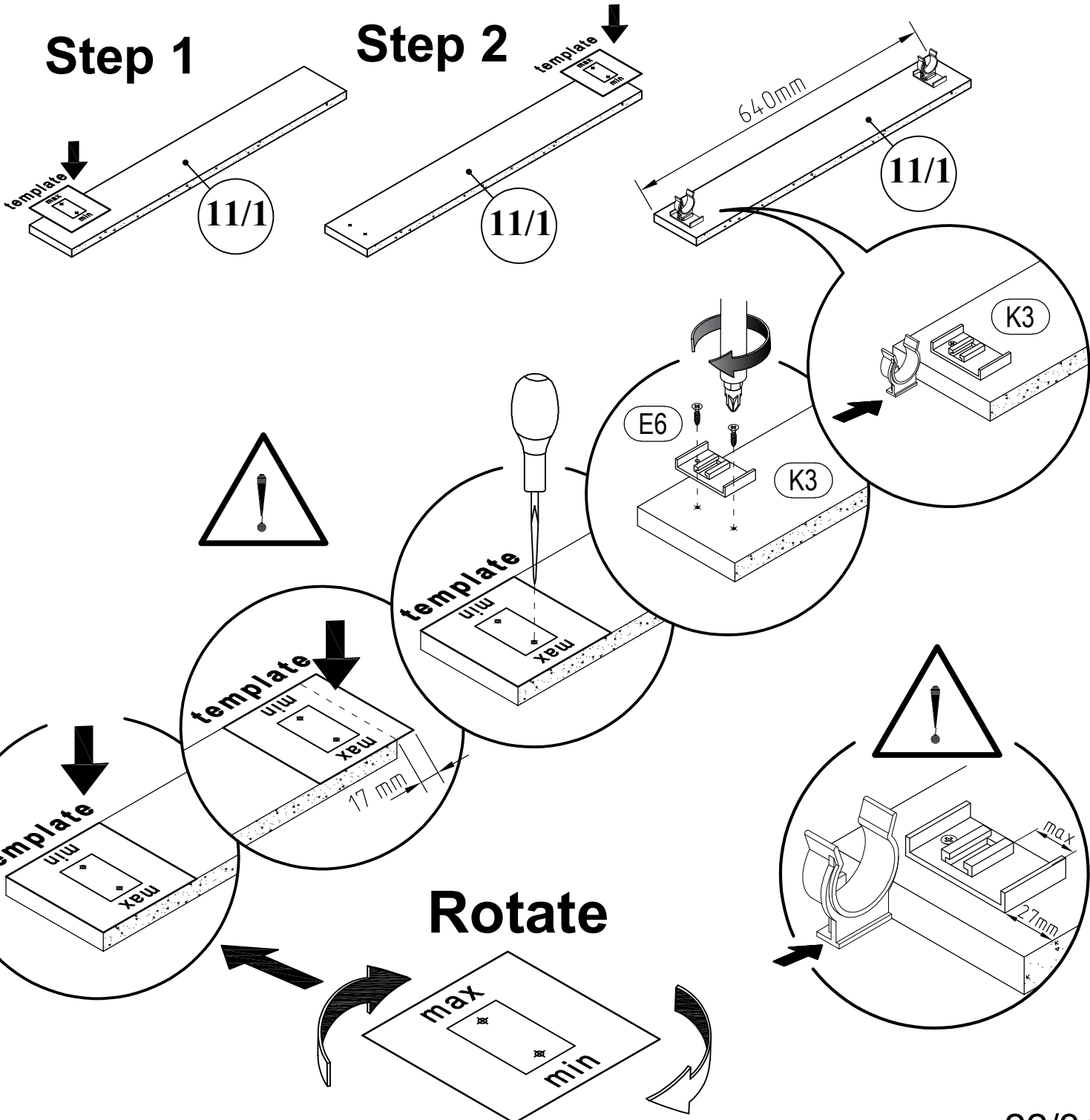



17

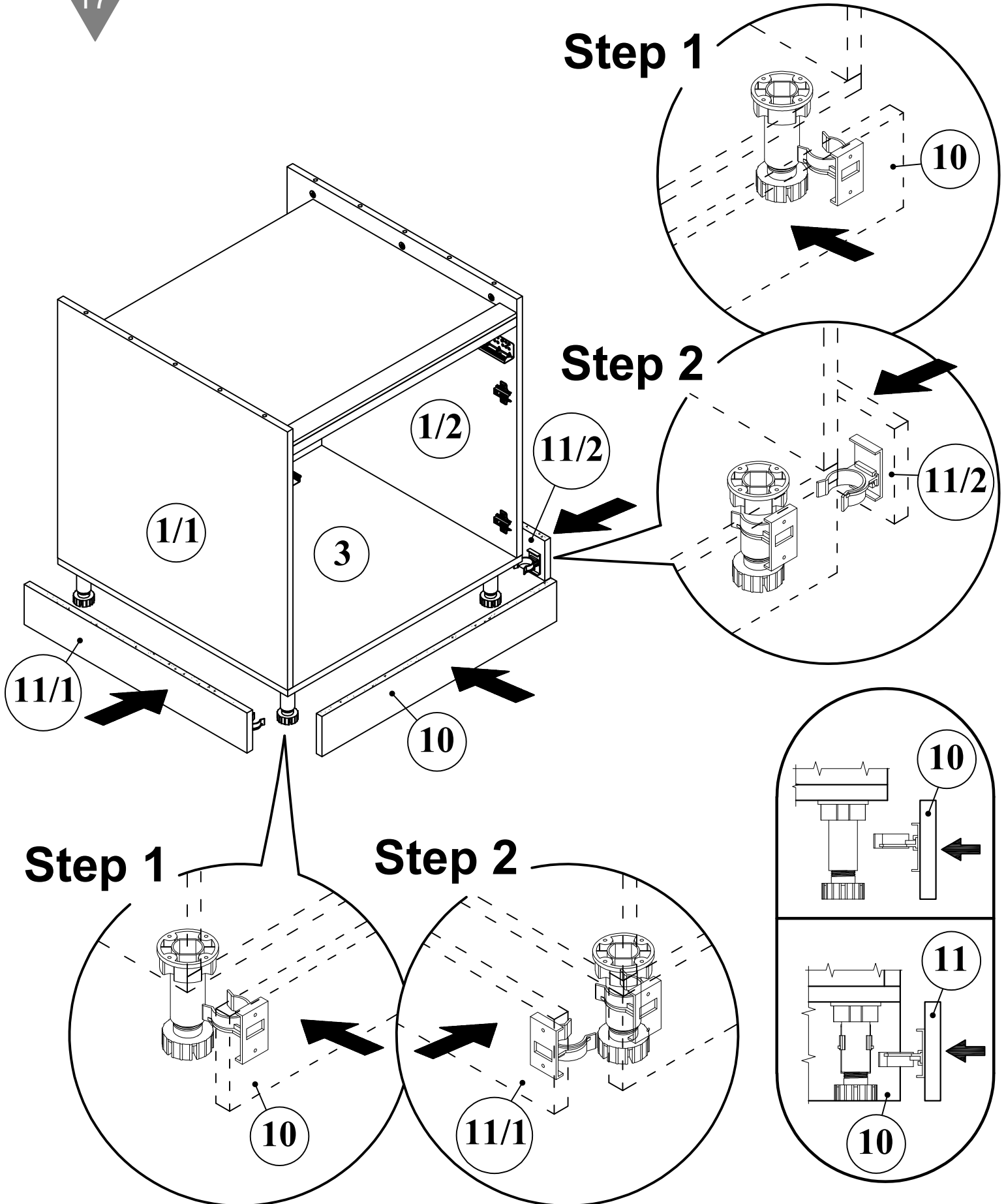





 (B) $\phi 12\text{mm}$ x4	 (B1) 6,3*50mm x4
-------------------------------	----------------------

18

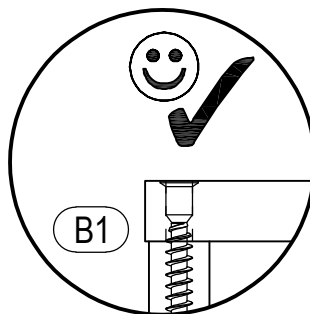
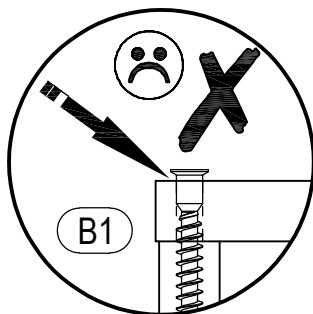
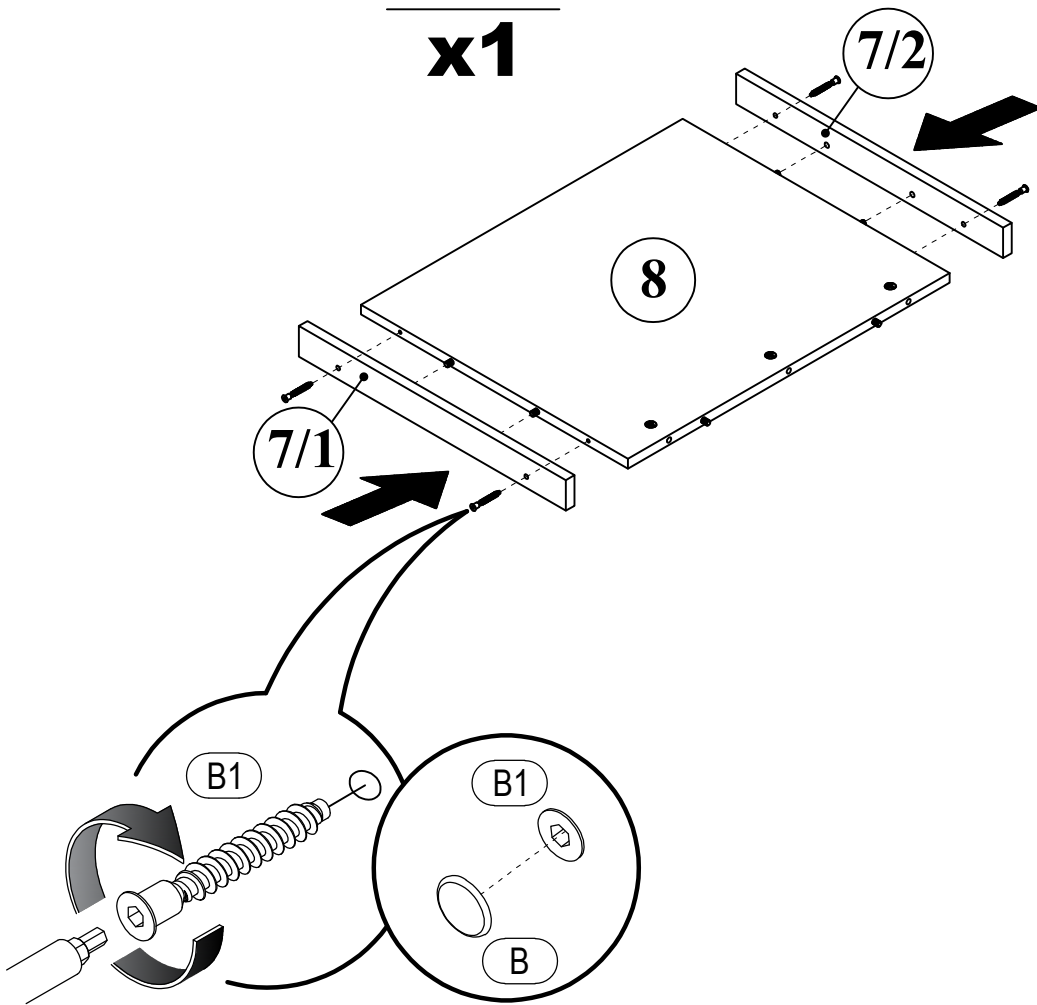
15.1
x1



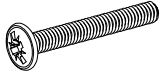
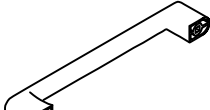

 D $\phi 20\text{mm}$ x3	 G9 M 4*25mm x2	 I59 F.412.104 x1
--	---	---

19

15.2
x1

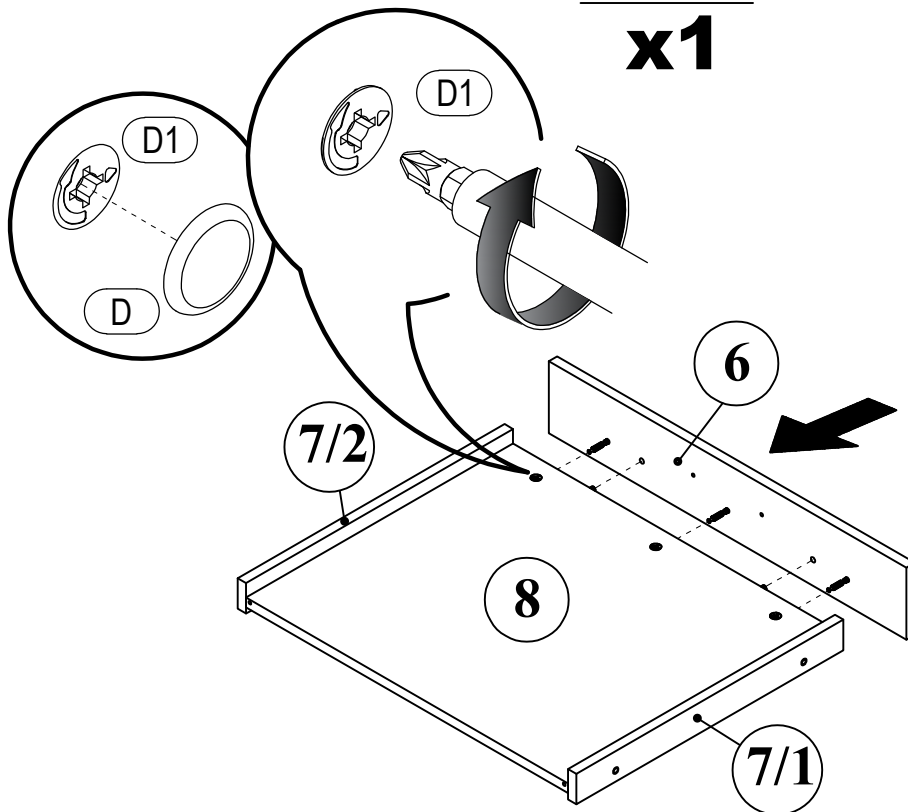

15.3
x1

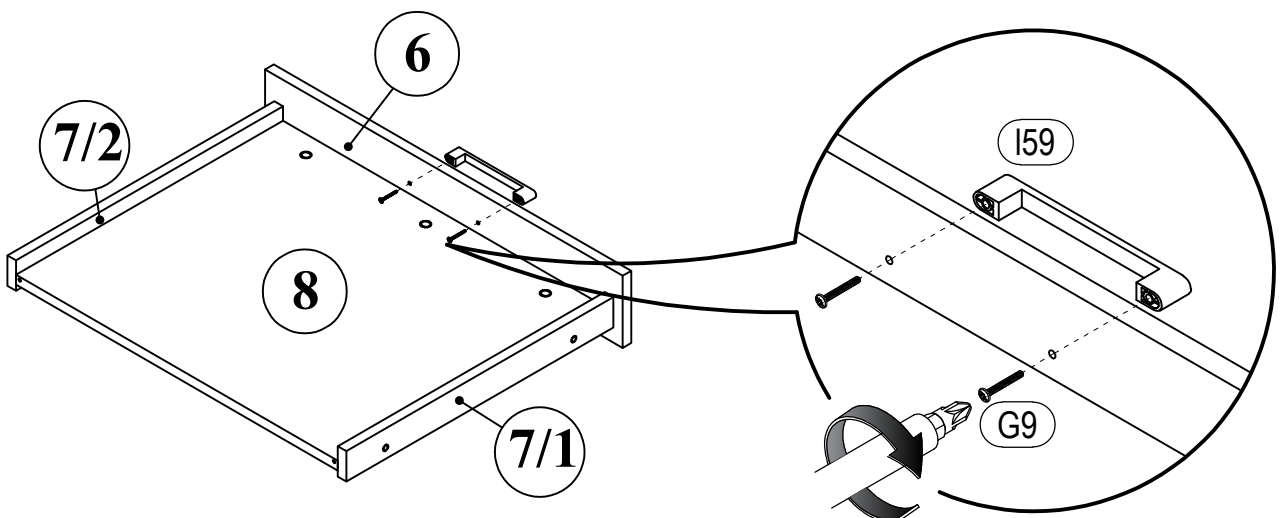



20

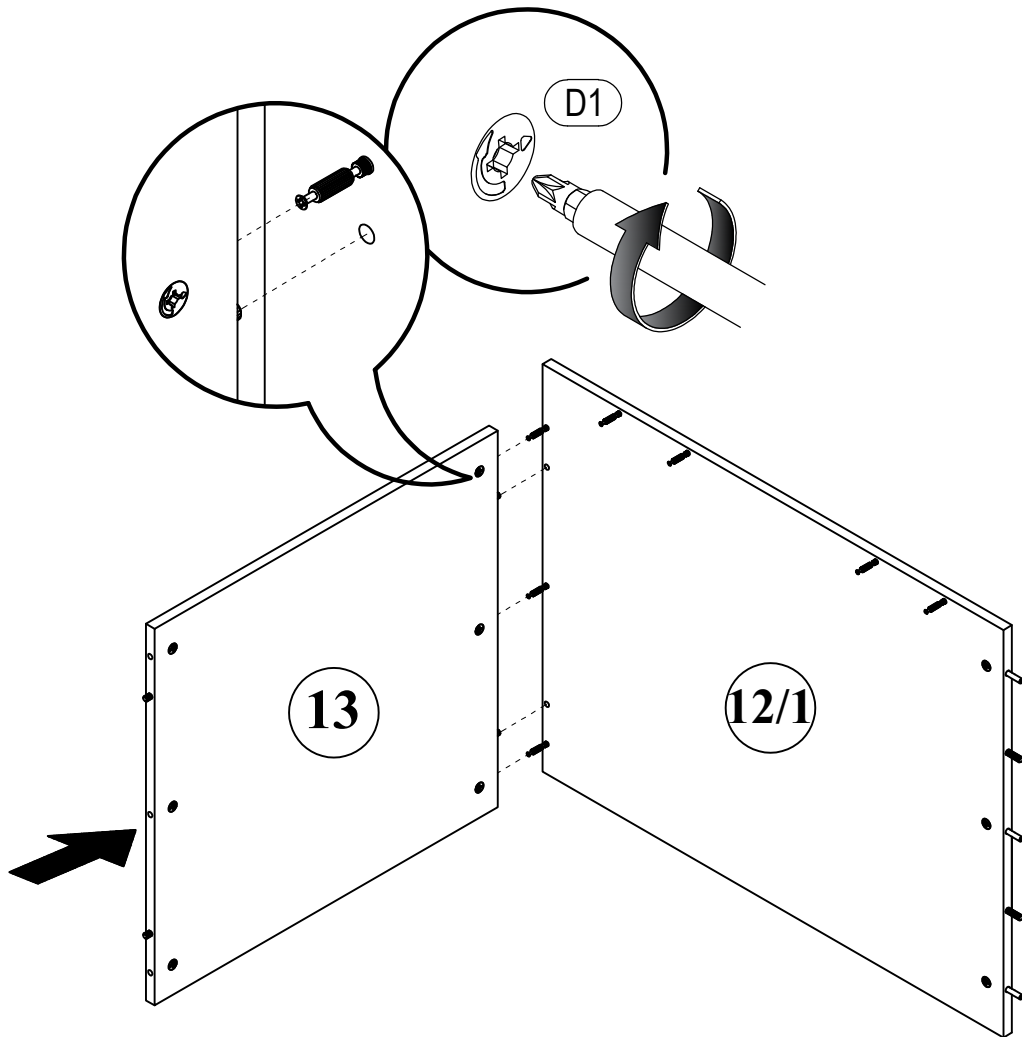



21

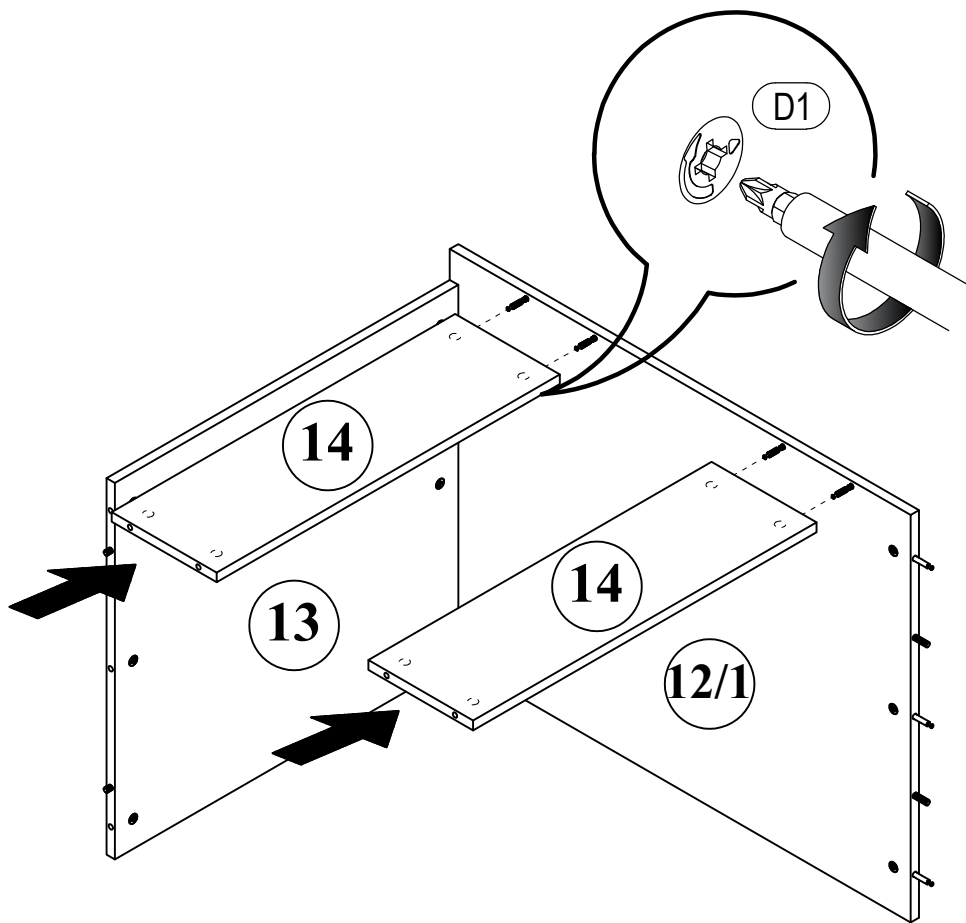



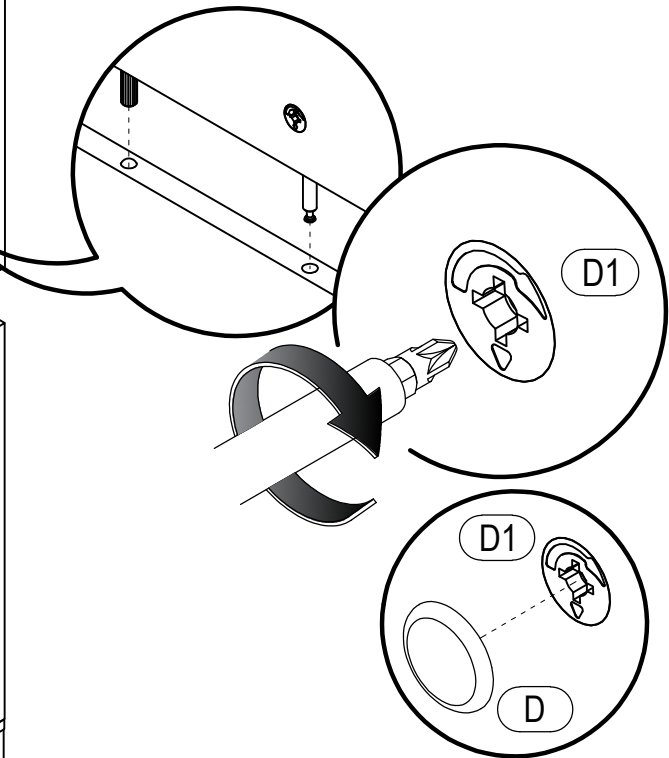
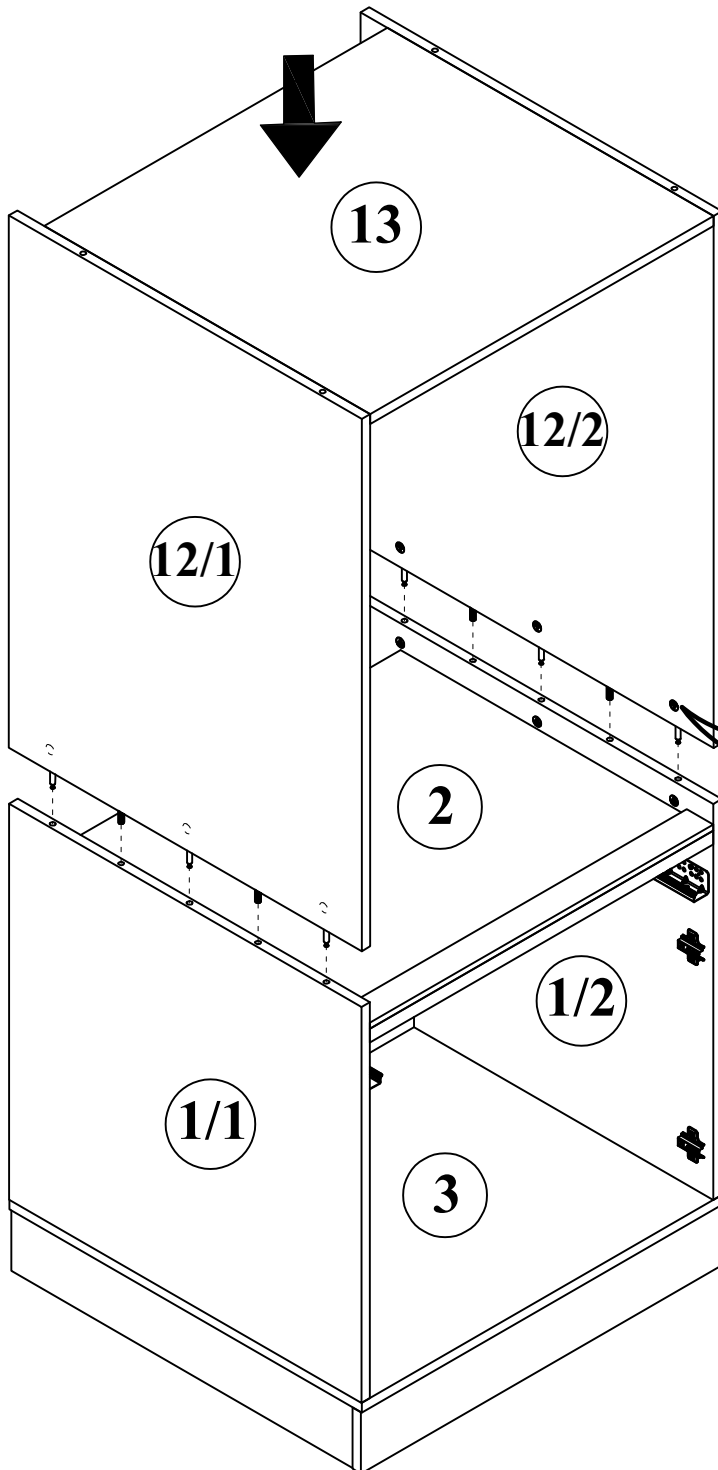
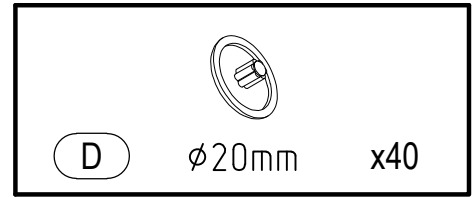

23



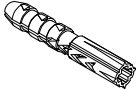
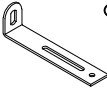

 (2E) 4,2*16mm x8	 (5E) 4,2*65mm x4	 (H5) 8*50mm x4
 (S16) 77x21x15 x4 Φ.229.02		

24

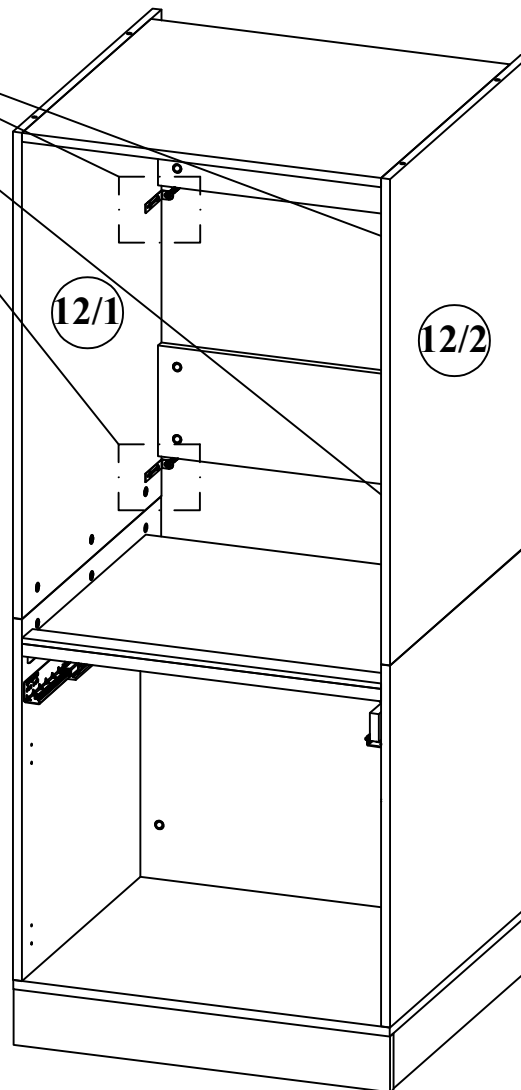
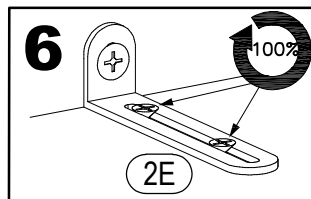
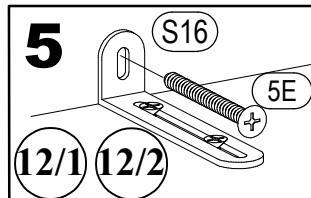
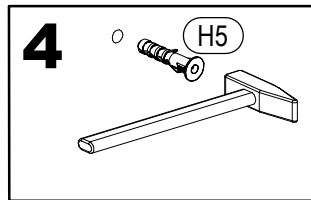
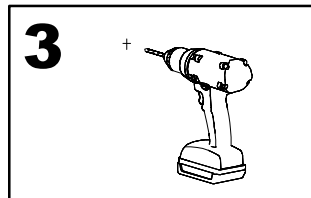
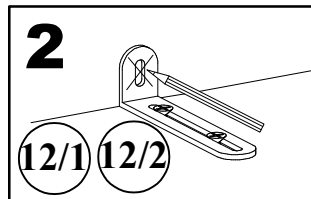
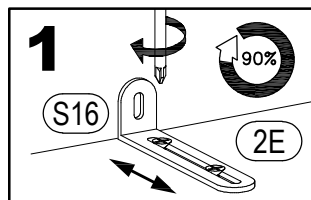



25

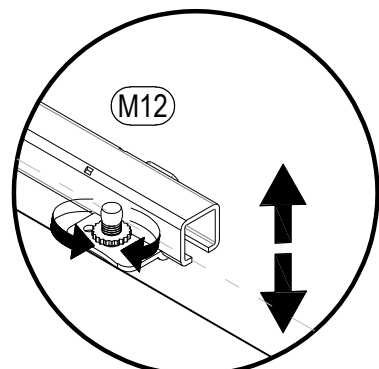
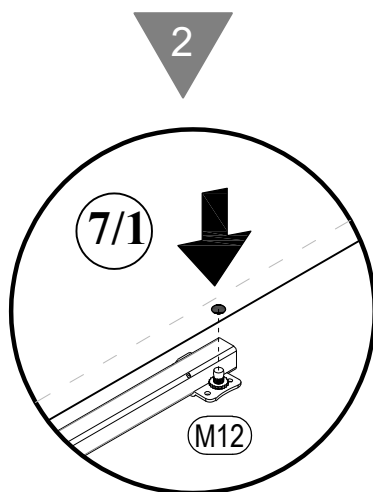
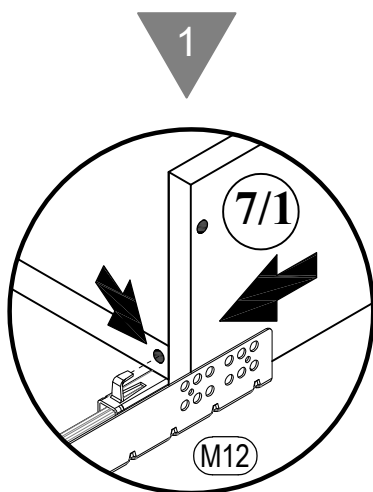
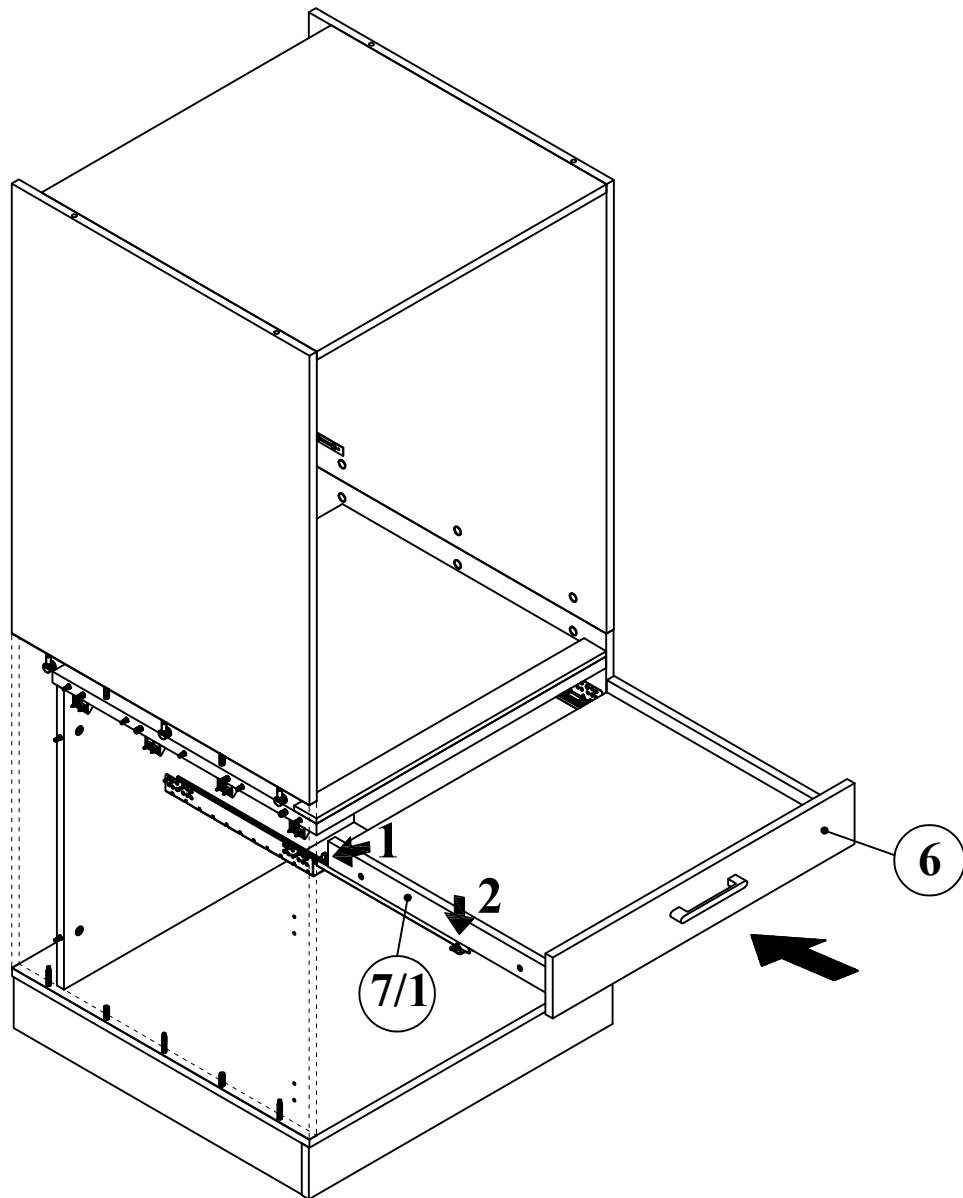

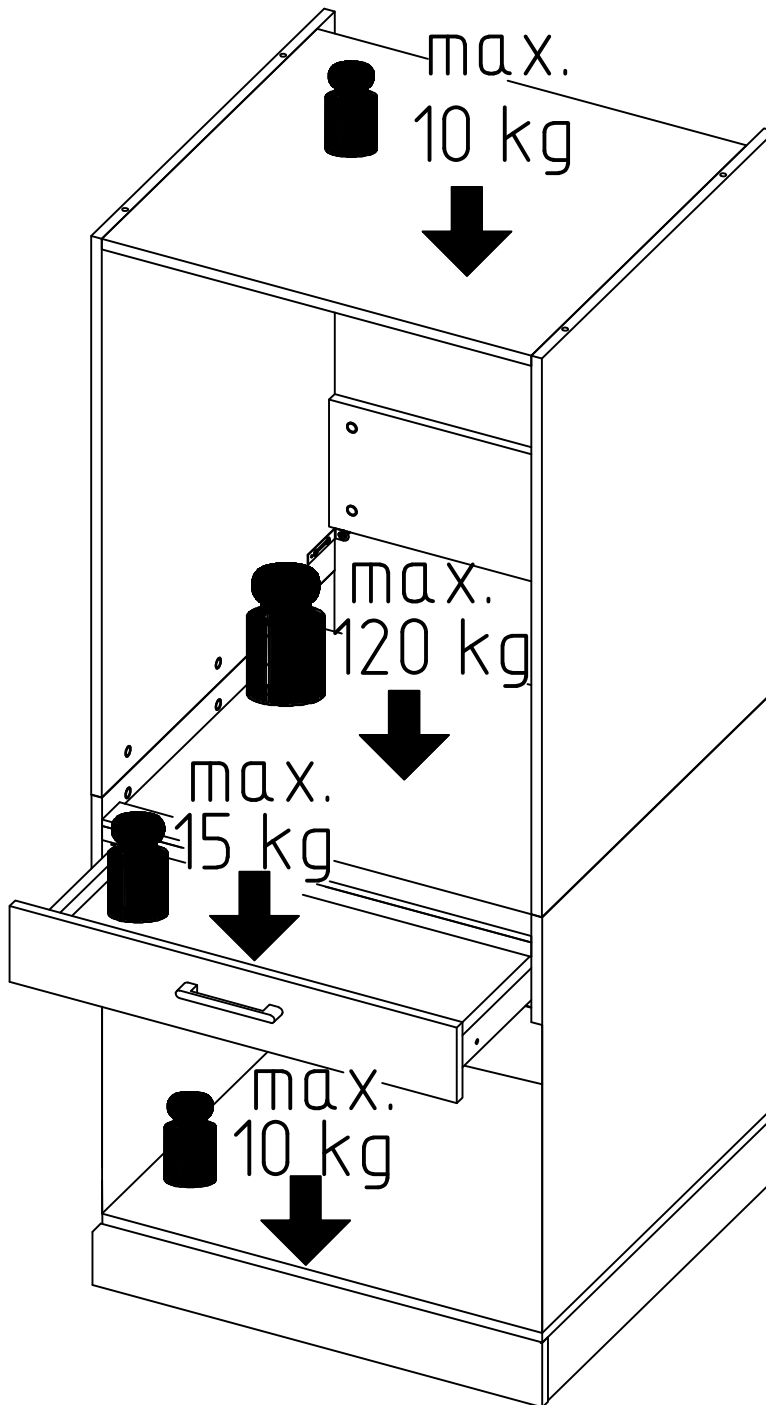
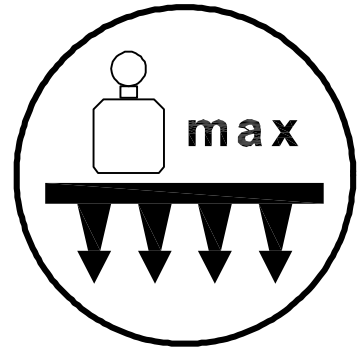

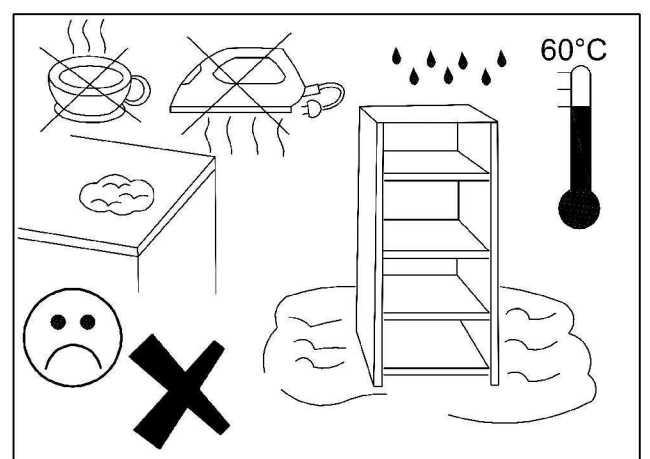
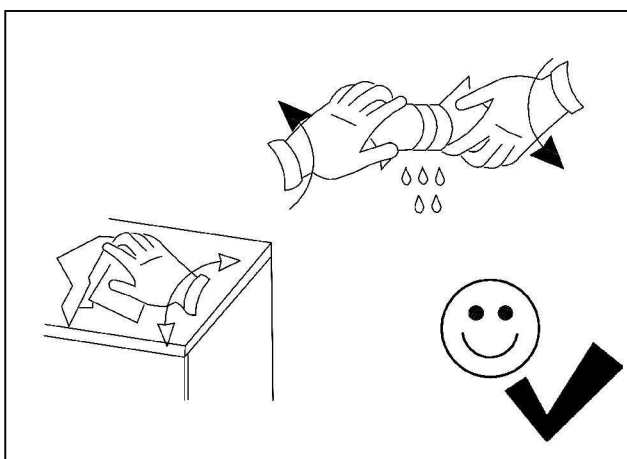
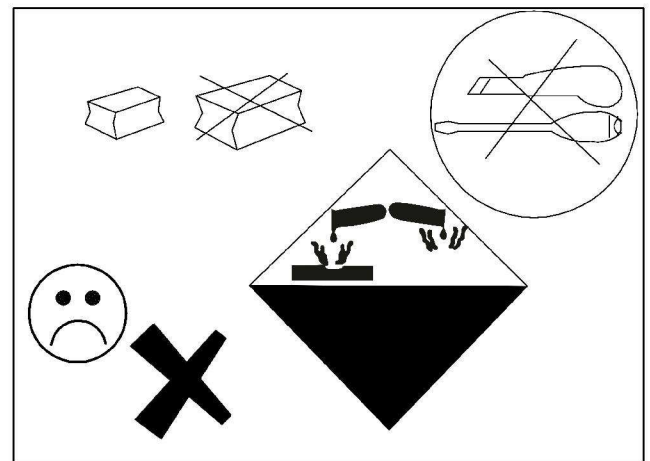
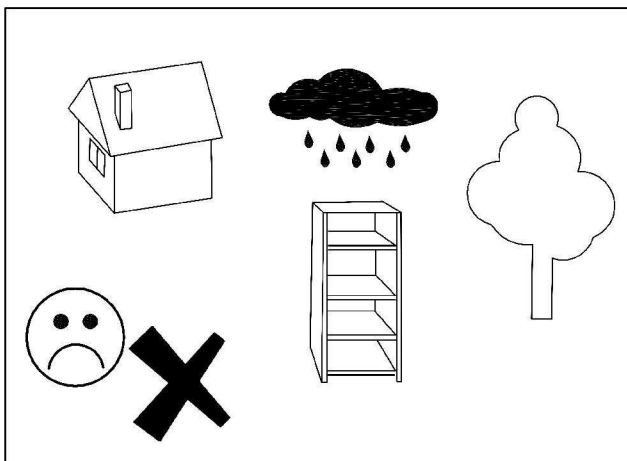
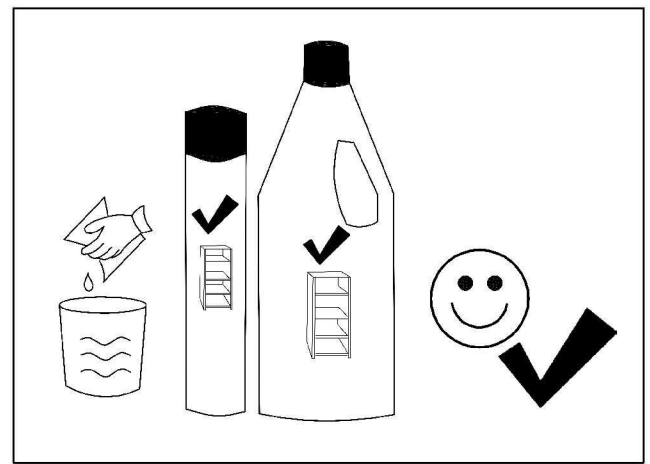
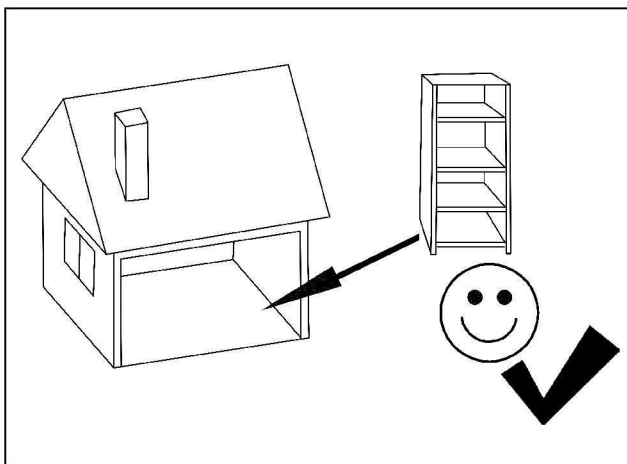
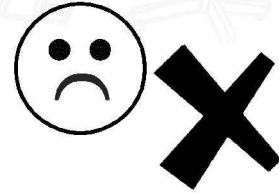
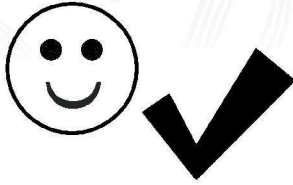

Vielen Dank für den Einkauf!

Thank you for shopping!

Fragen oder Probleme?

Wir helfen unter vcm.group/service

Questions or problems? Visit vcm.group/service



DE Als Familienunternehmen aus dem süddeutschen Dreiländereck (Deutschland / Schweiz / Frankreich), haben wir uns seit den 70er Jahren auf die nachhaltige Konstruktion, Produktion und Vertrieb von Möbeln zu fairen Preisen spezialisiert.

Damit wir das eigene Zuhause auch in Zukunft lebenswert gestalten dürfen, sind wir auf Bewertungen angewiesen. Unser Team freut sich daher ganz besonders über eine Bewertung.

EN As a family business from the southern German border triangle (Germany / Switzerland / France), we have specialized in the sustainable construction, production and sale of furniture at fair prices since the 1970s.

In order to continue making your home livable in the future, we rely on positive feedback and welcome every customer review.

FR En tant qu'entreprise familiale du triangle frontalier du sud de l'Allemagne (Allemagne / Suisse / France), nous nous sommes spécialisés dans la construction, la production et la vente durables de meubles à des prix équitables depuis les années 1970.

Afin de continuer à rendre votre maison habitable à l'avenir, nous comptons sur vos commentaires positifs et accueillons votre avis client.

NL Als familiebedrijf uit het Zuid-Duitse drielandenpunt (Duitsland / Zwitserland / Frankrijk) zijn wij sinds de jaren 70 gespecialiseerd in het duurzaam bouwen, produceren en verkopen van meubelen tegen eerlijke prijzen.

Om uw huis ook in de toekomst leefbaar te blijven maken, vertrouwen wij op uw positieve feedback en verwelkomen wij uw klantbeoordeling.

VCM.
my bath